



US 20140124765A1

(19) **United States**

(12) **Patent Application Publication**
Omoto

(10) **Pub. No.: US 2014/0124765 A1**
(43) **Pub. Date: May 8, 2014**

(54) **ORGANIC EL DISPLAY DEVICE AND ELECTRONIC APPARATUS**

Publication Classification

(71) Applicant: **Sony Corporation**, Tokyo (JP)

(51) **Int. Cl.**
H01L 27/32 (2006.01)

(72) Inventor: **Keisuke Omoto**, Kanagawa (JP)

(52) **U.S. Cl.**
CPC **H01L 27/3248** (2013.01)
USPC **257/40**

(73) Assignee: **Sony Corporation**, Tokyo (JP)

(57) **ABSTRACT**

(21) Appl. No.: **14/072,098**

Disclosed herein is an organic EL display device in which pixels each including an organic EL element formed by interposing an organic layer between an anode electrode and a cathode electrode are arranged in a matrix, the organic EL display device including: a common layer configured to be included in the organic EL element and be formed in the organic layer in common to the pixels; and a metal interconnect configured to surround periphery of the anode electrode and be electrically connected to the organic layer, wherein potential of the metal interconnect is set to a potential lower than potential of the anode electrode in a non-light-emission state of the organic EL element.

(22) Filed: **Nov. 5, 2013**

Related U.S. Application Data

(63) Continuation of application No. 13/305,308, filed on Nov. 28, 2011, now Pat. No. 8,581,275.

Foreign Application Priority Data

(30) Jan. 25, 2011 (JP) 2011-013049

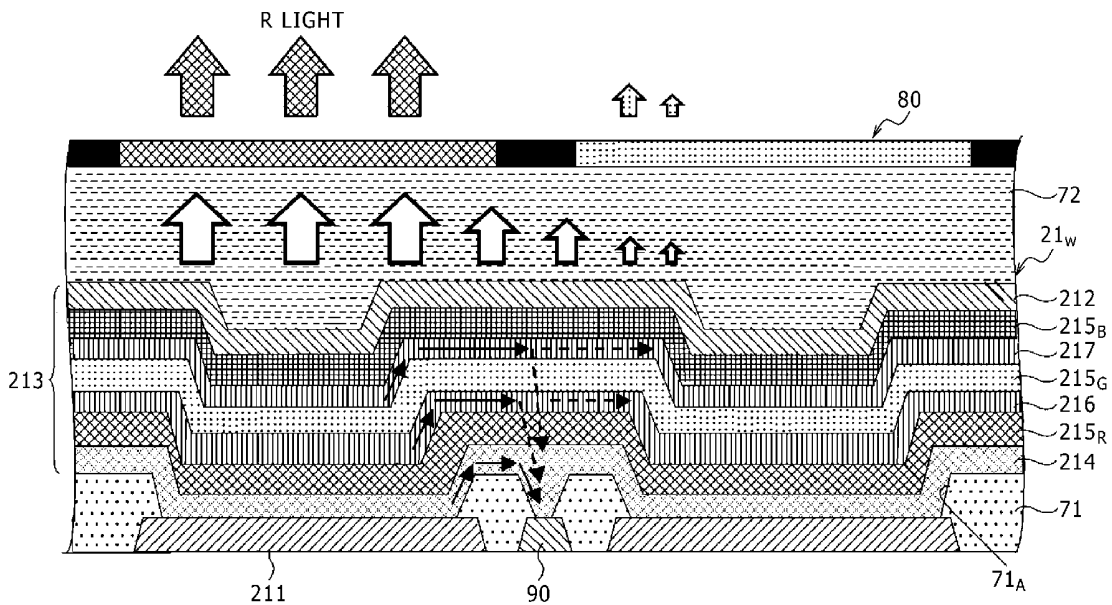

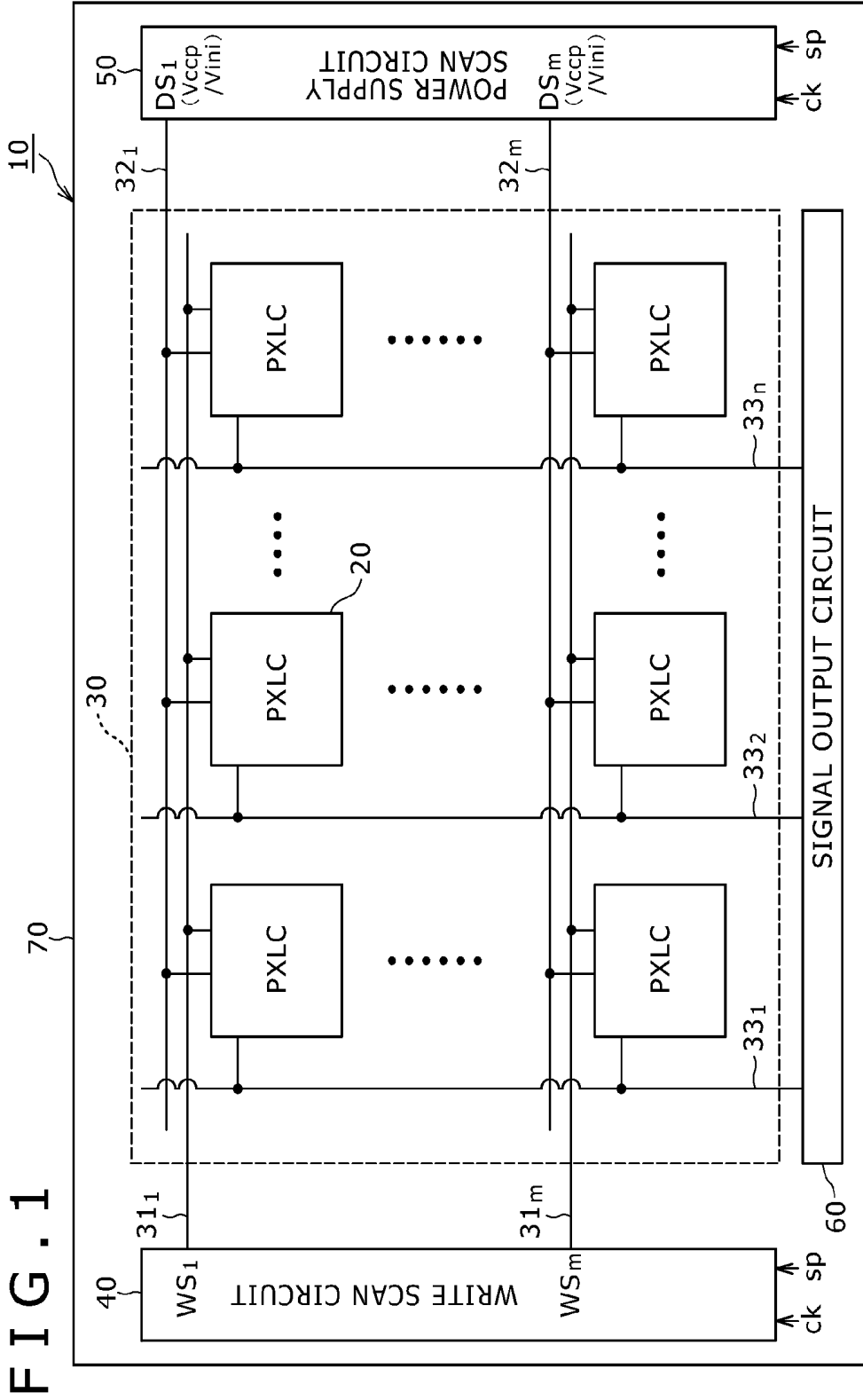

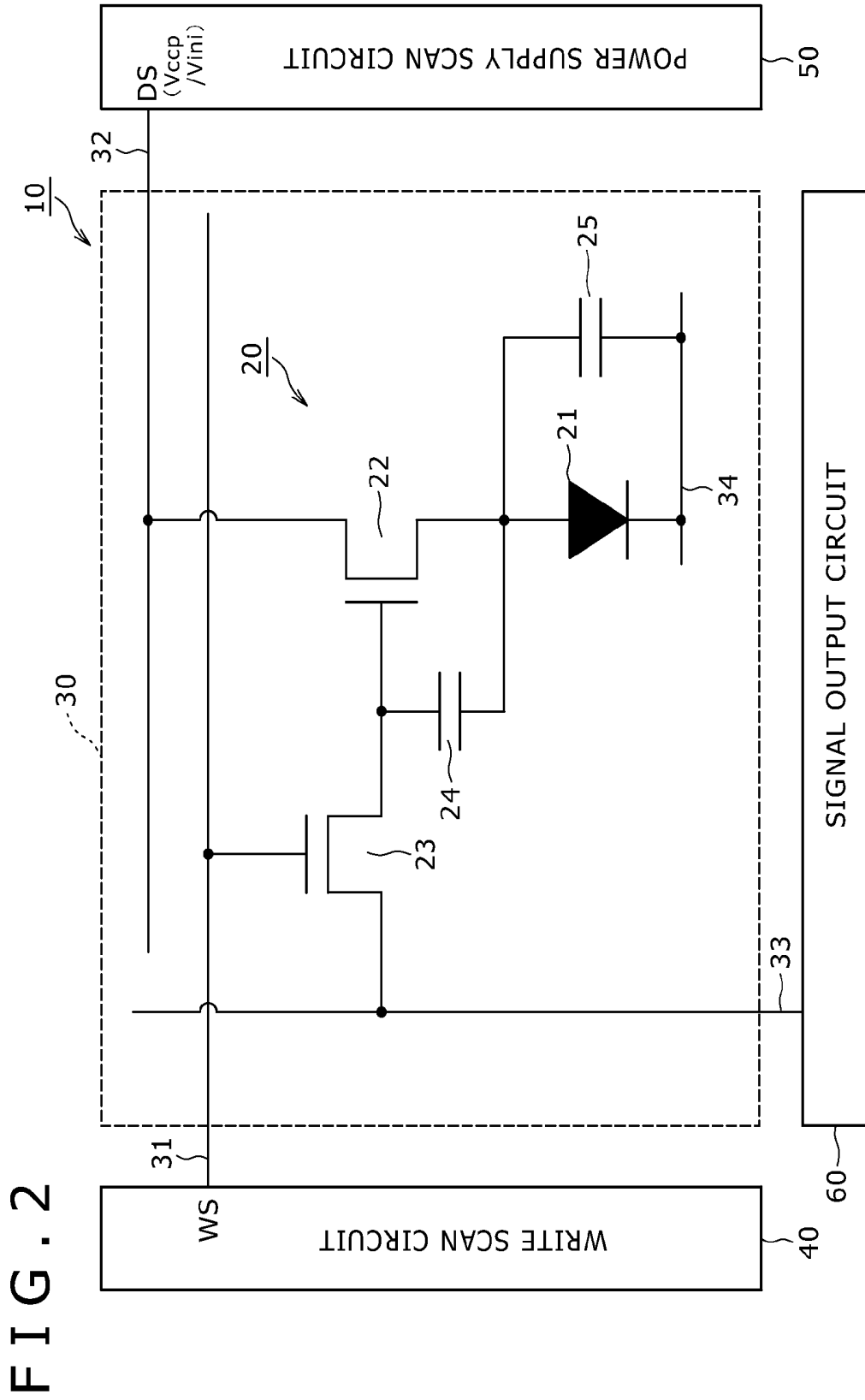

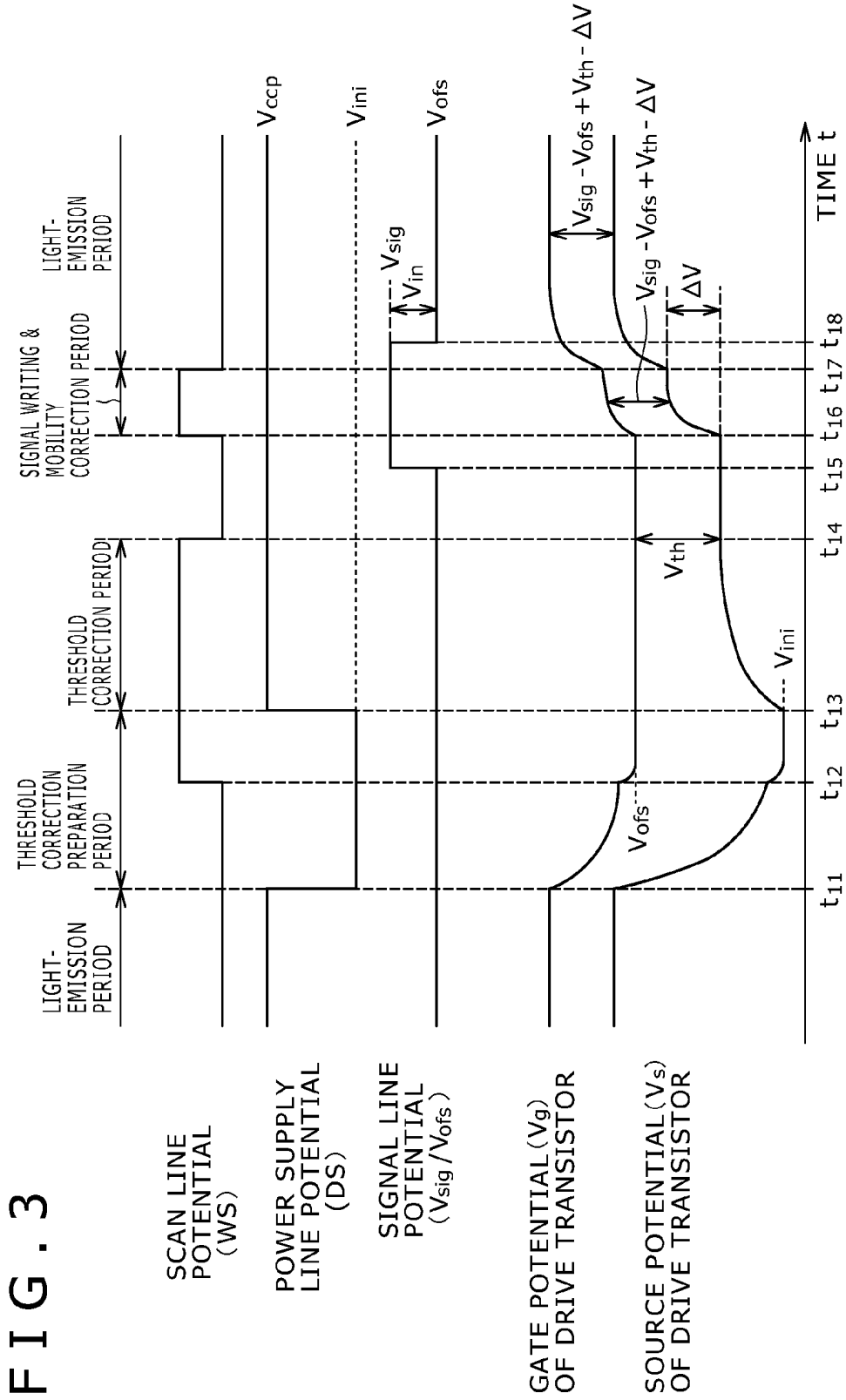

FIG. 4A

BEFORE $t=t_{11}$

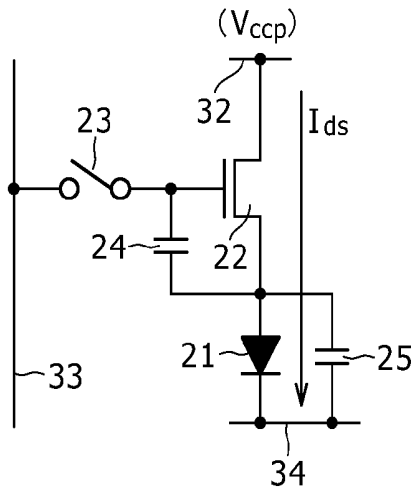

FIG. 4B

$t=t_{11}$

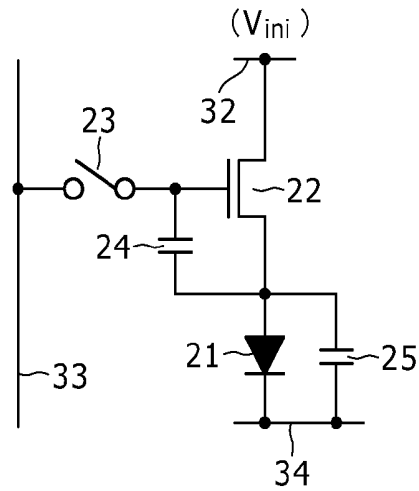

FIG. 4C

$t=t_{12}$

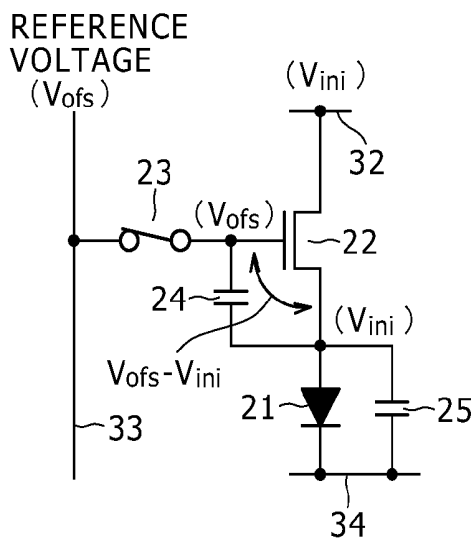

FIG. 4D

$t=t_{13}$

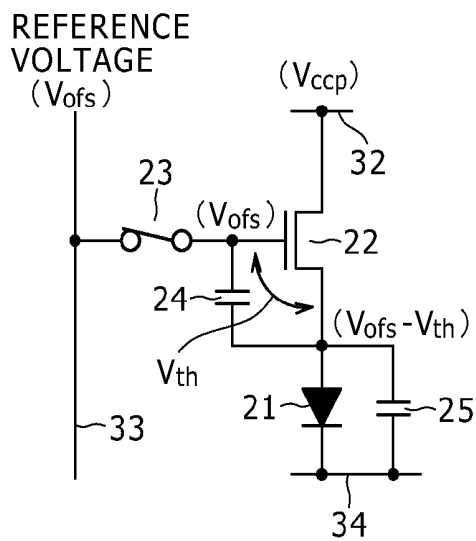

FIG. 5A

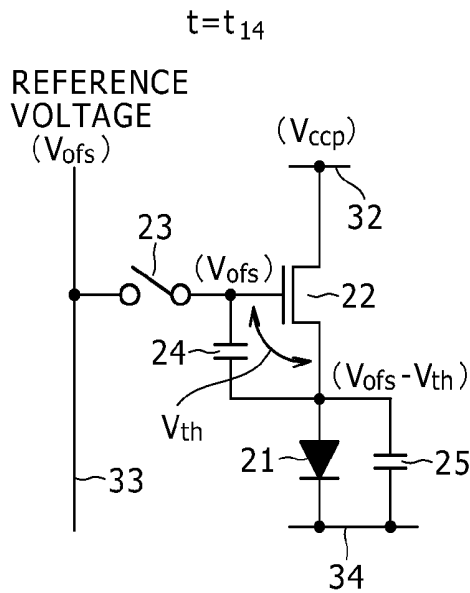

FIG. 5B

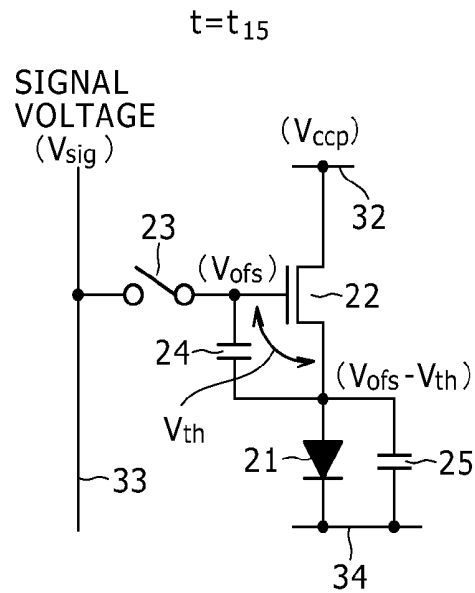

FIG. 5C

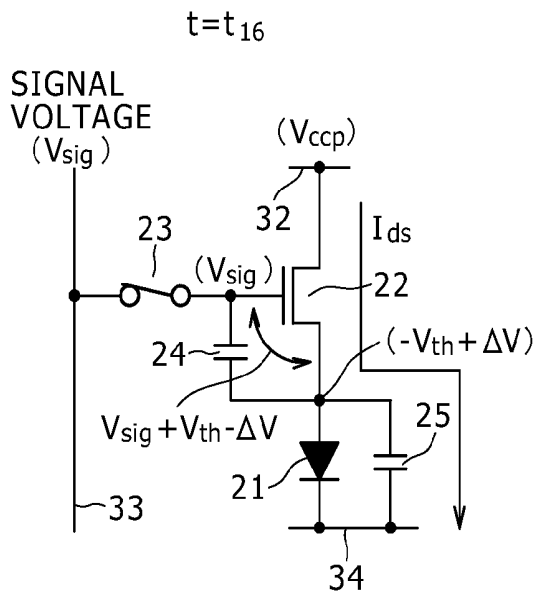

FIG. 5D

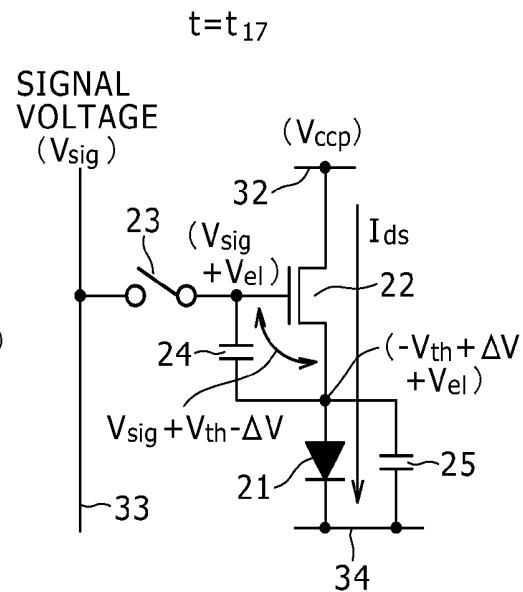

FIG. 6A

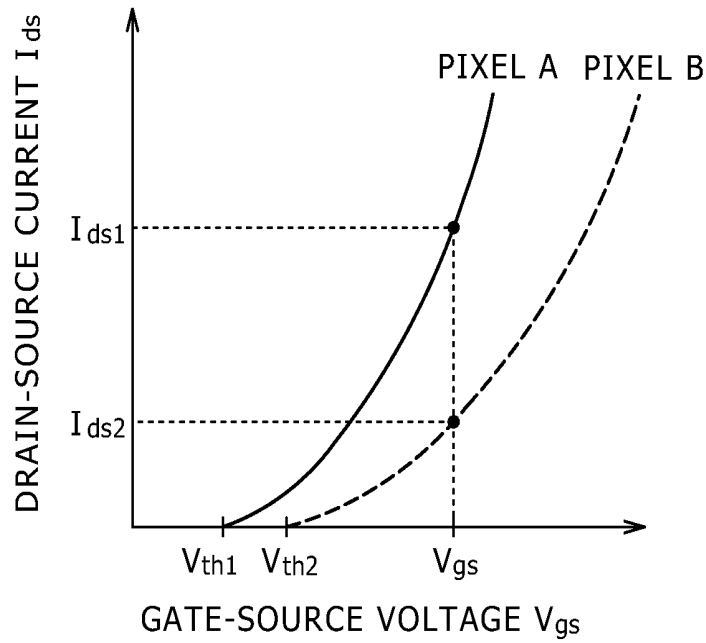

FIG. 6B

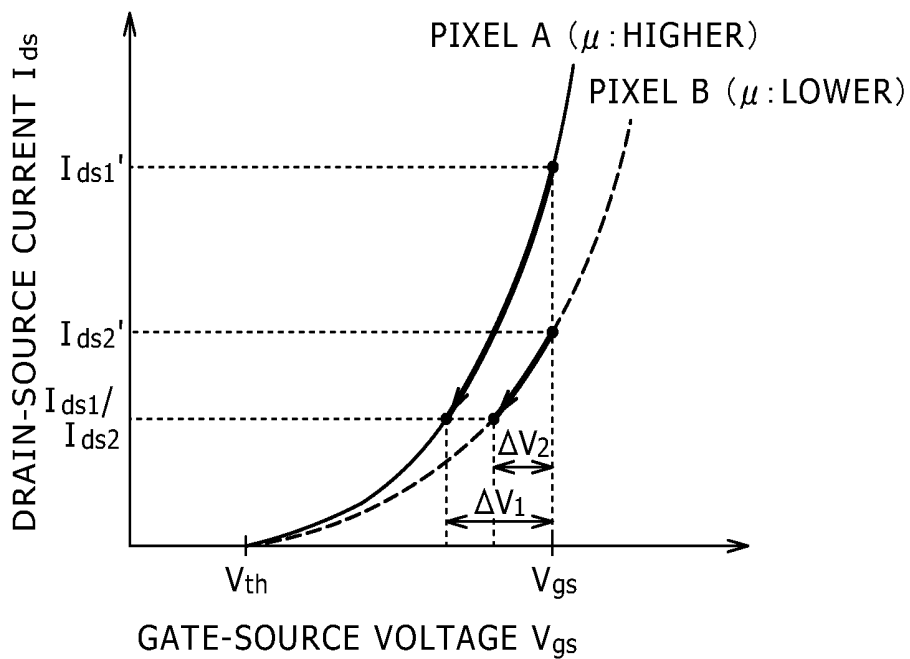

FIG. 7

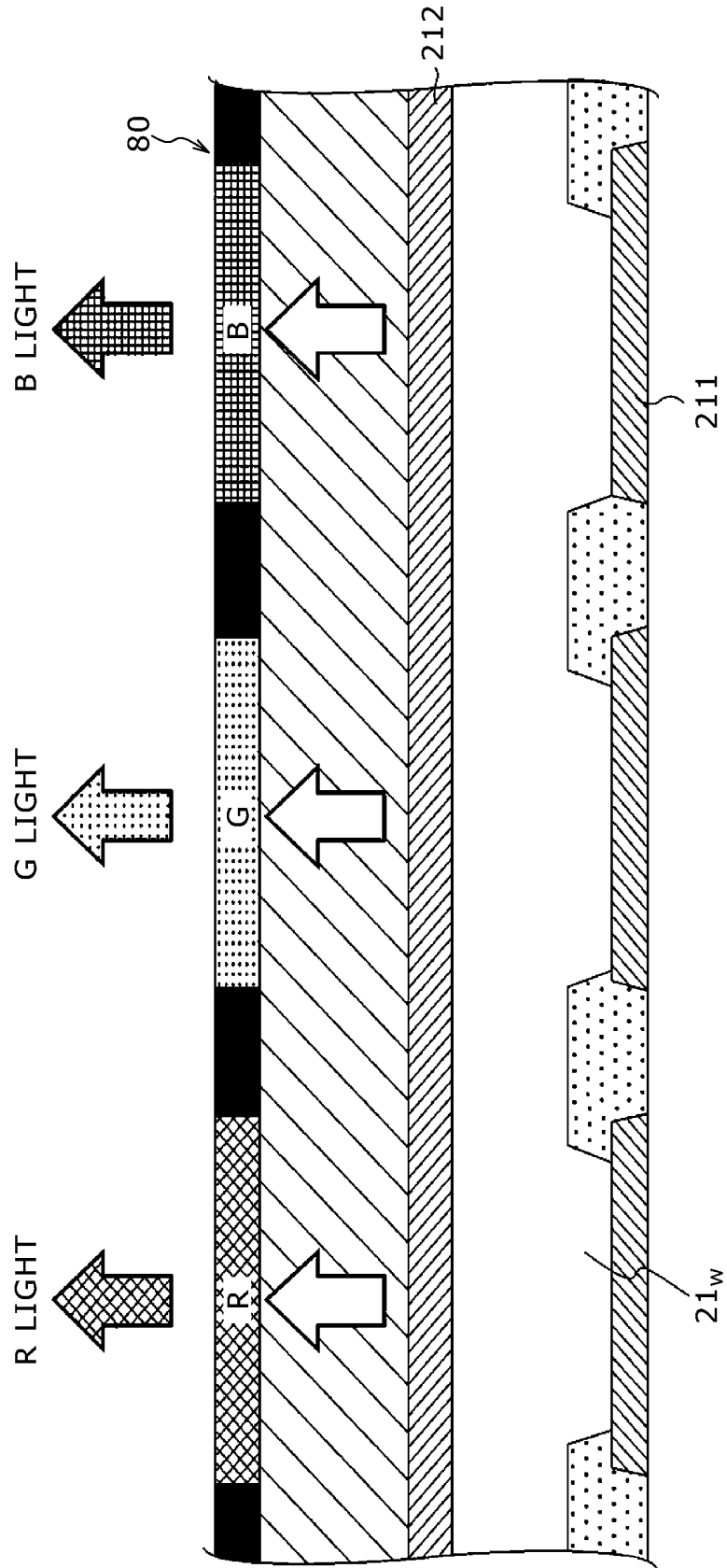

FIG. 8

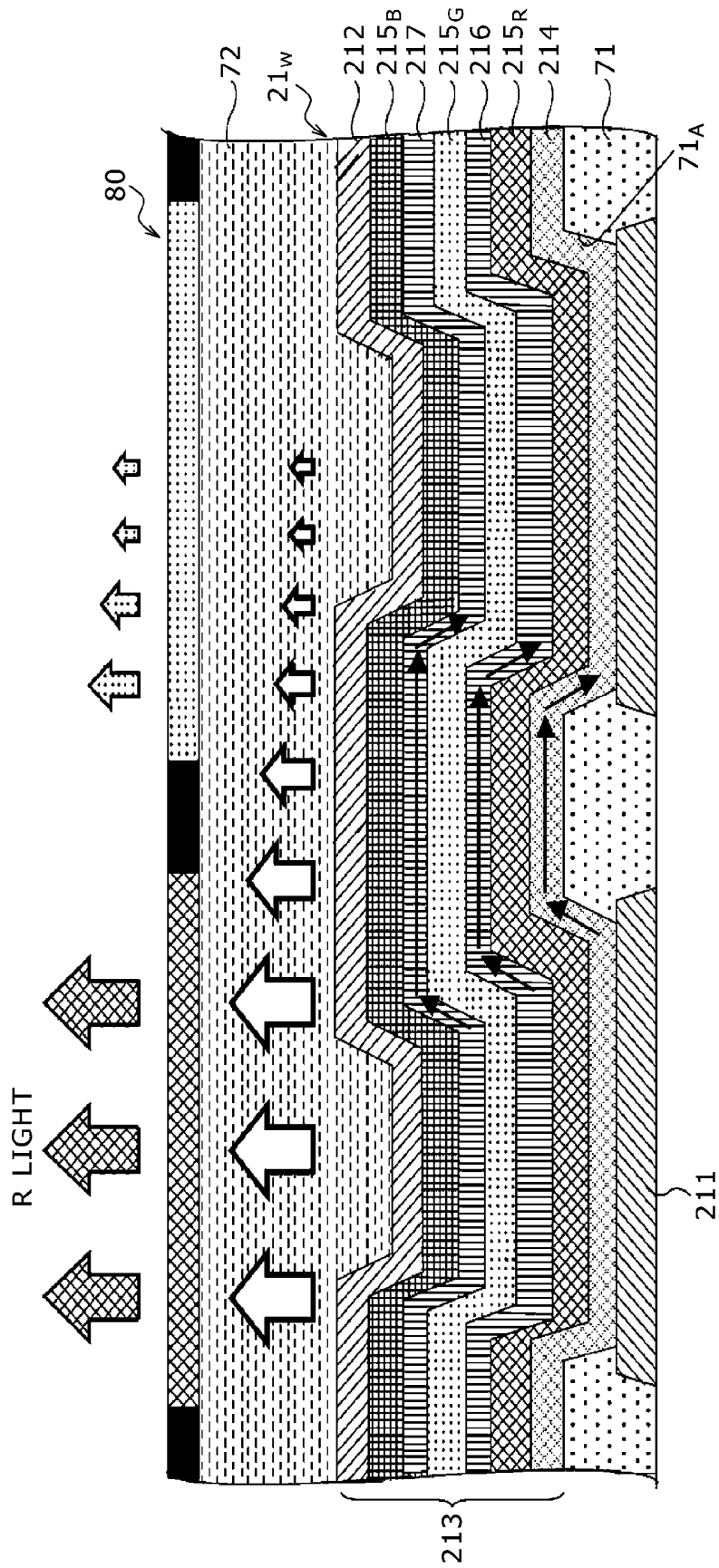

FIG. 9

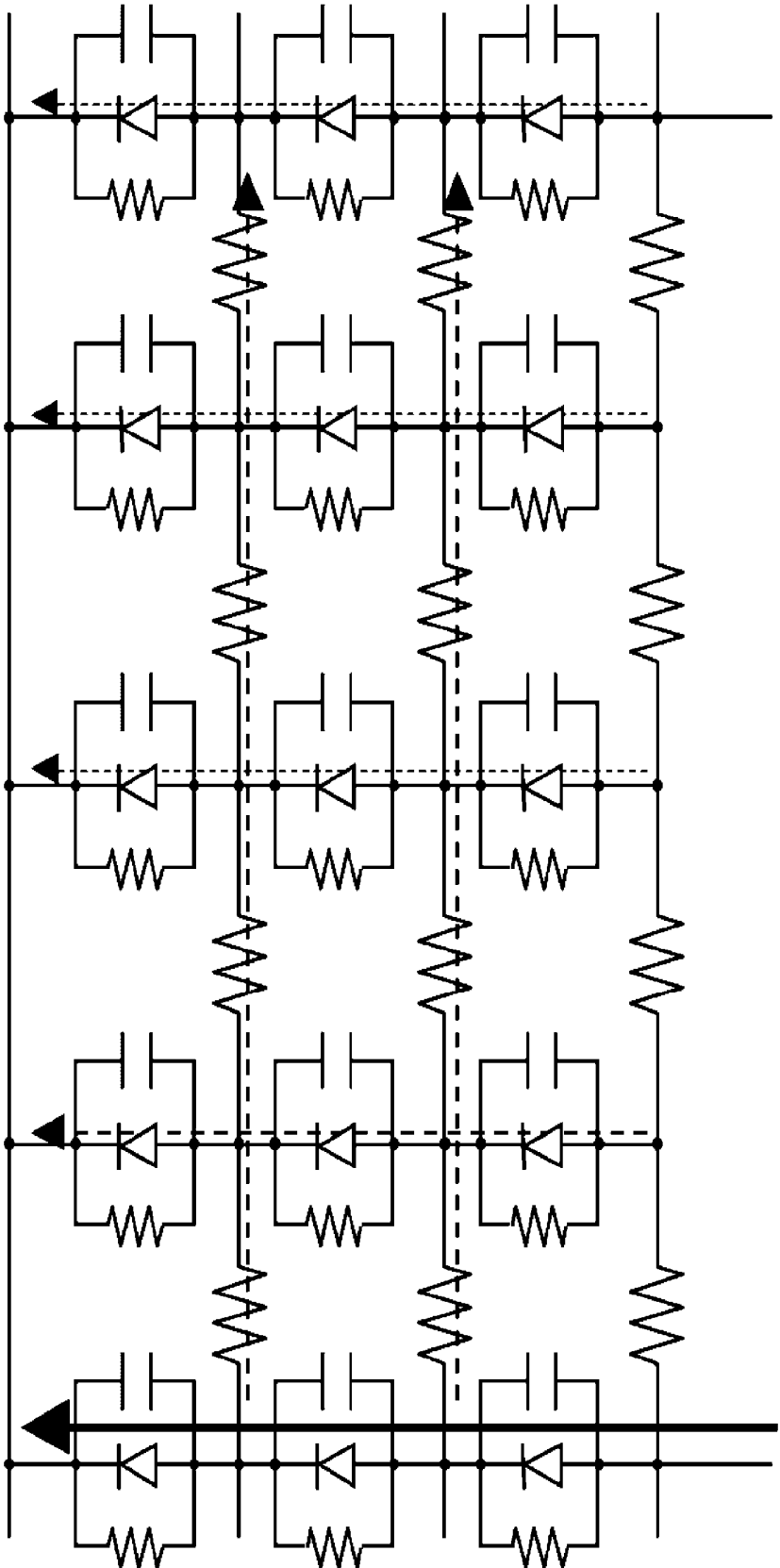

FIG. 10

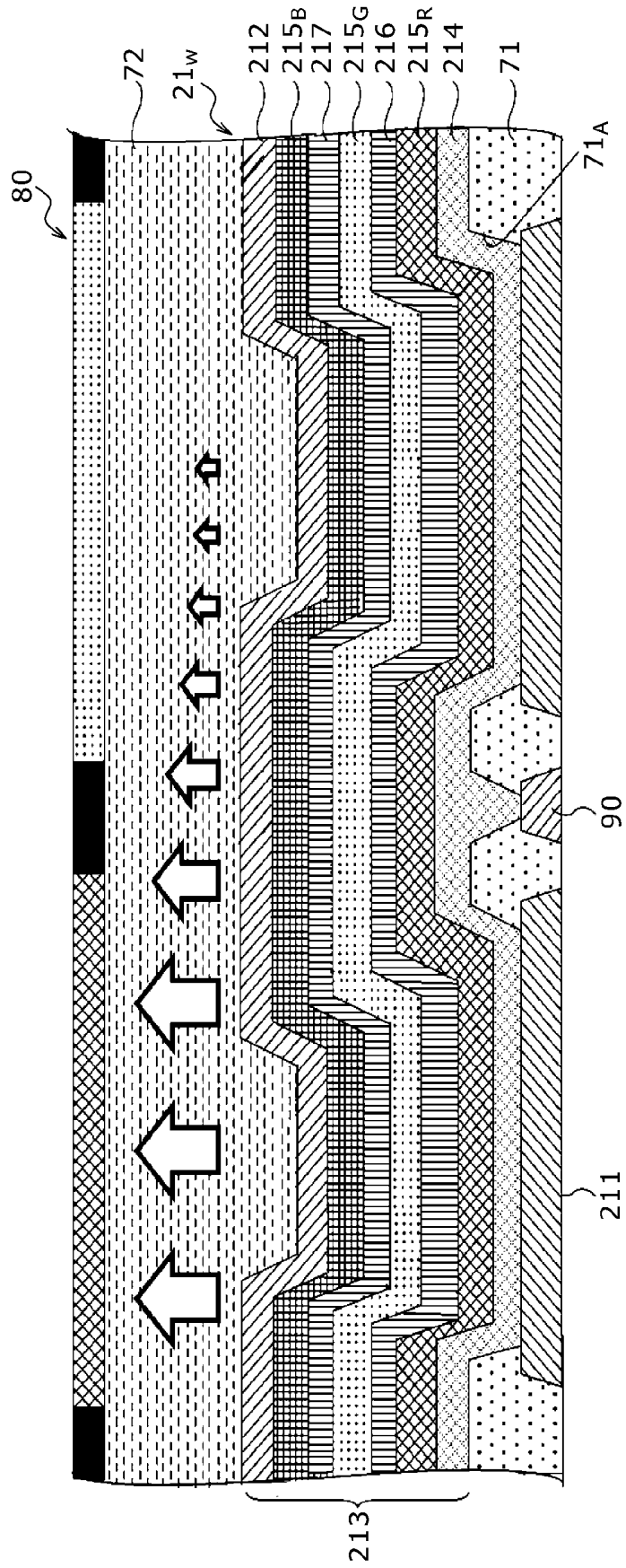

FIG. 11

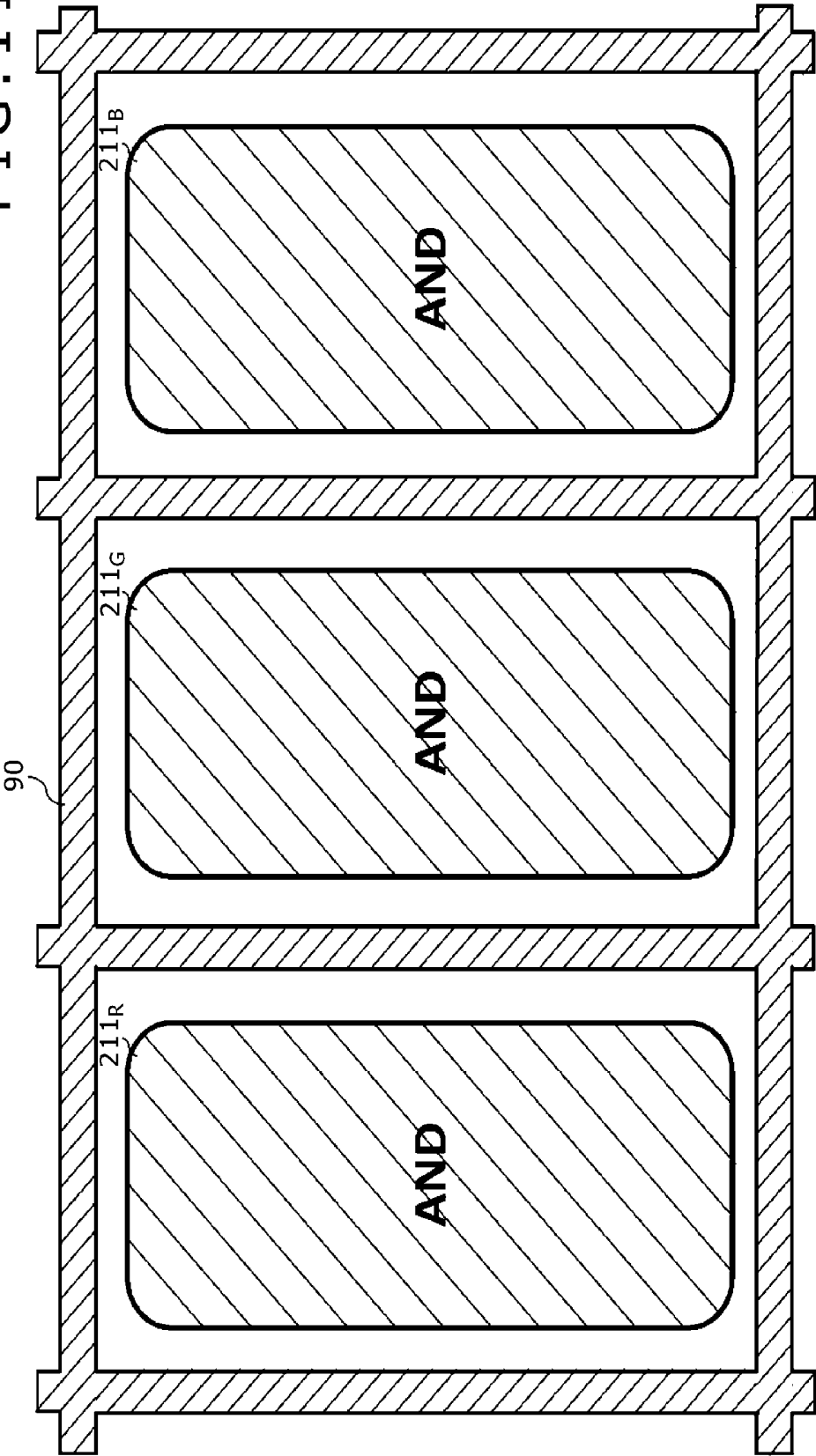

FIG. 12

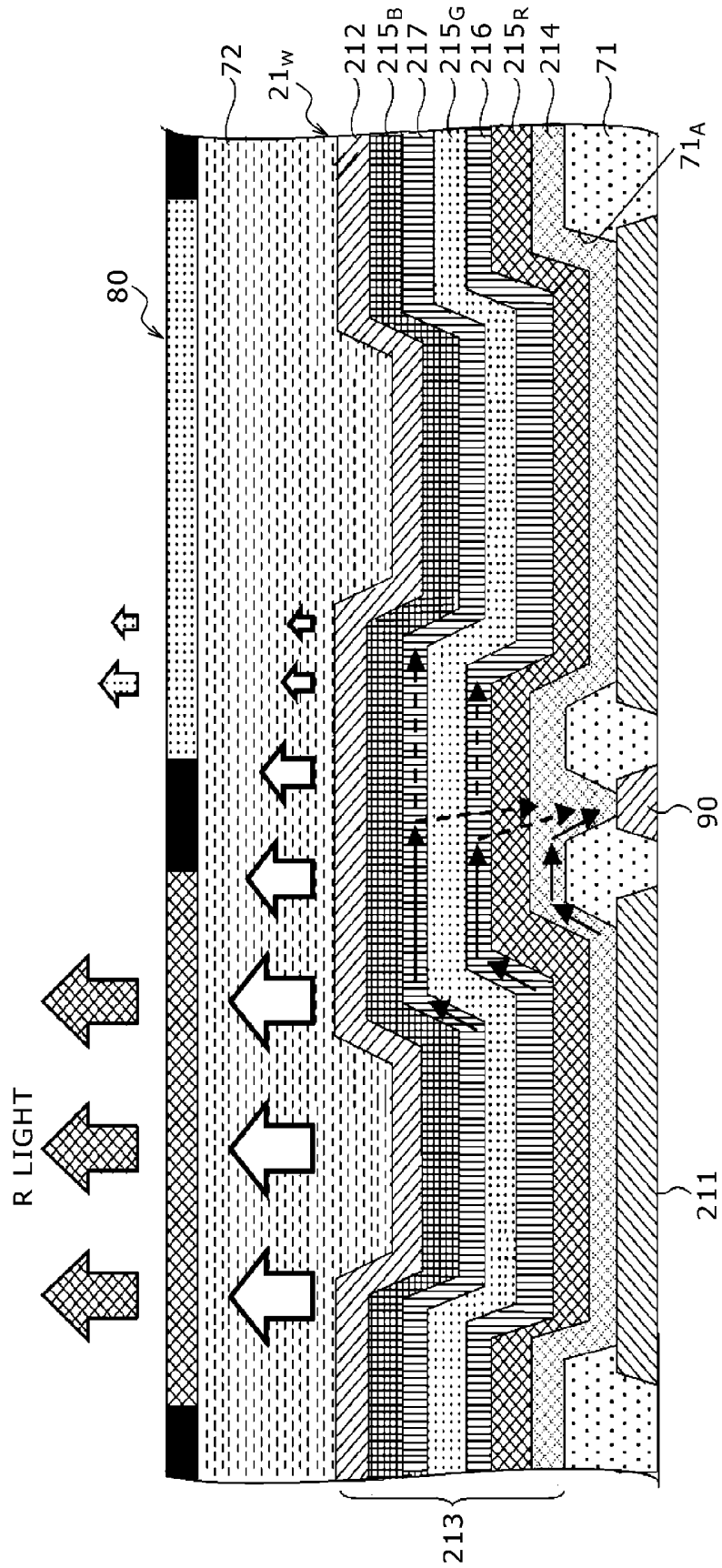

FIG. 13

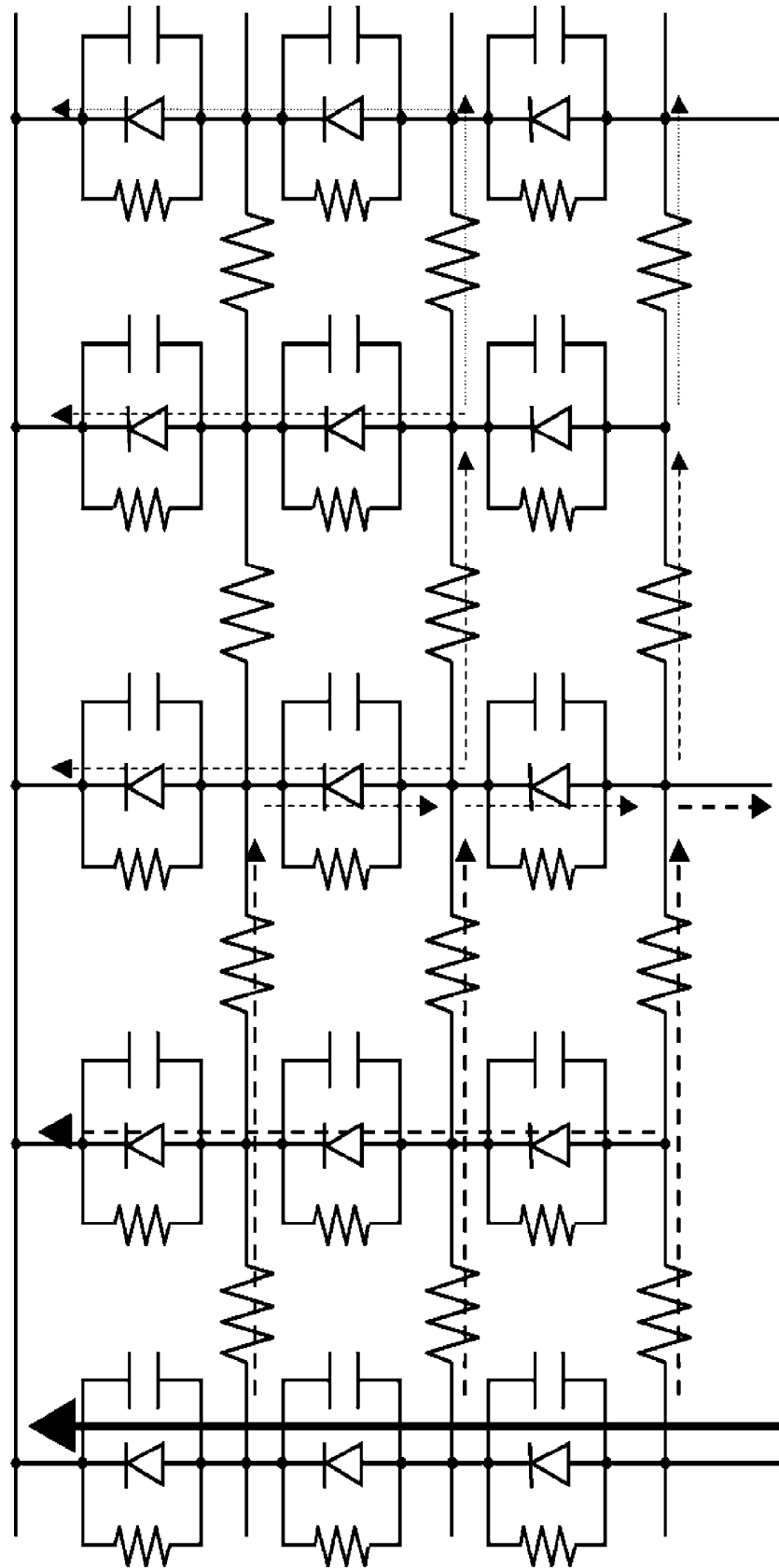

FIG. 14

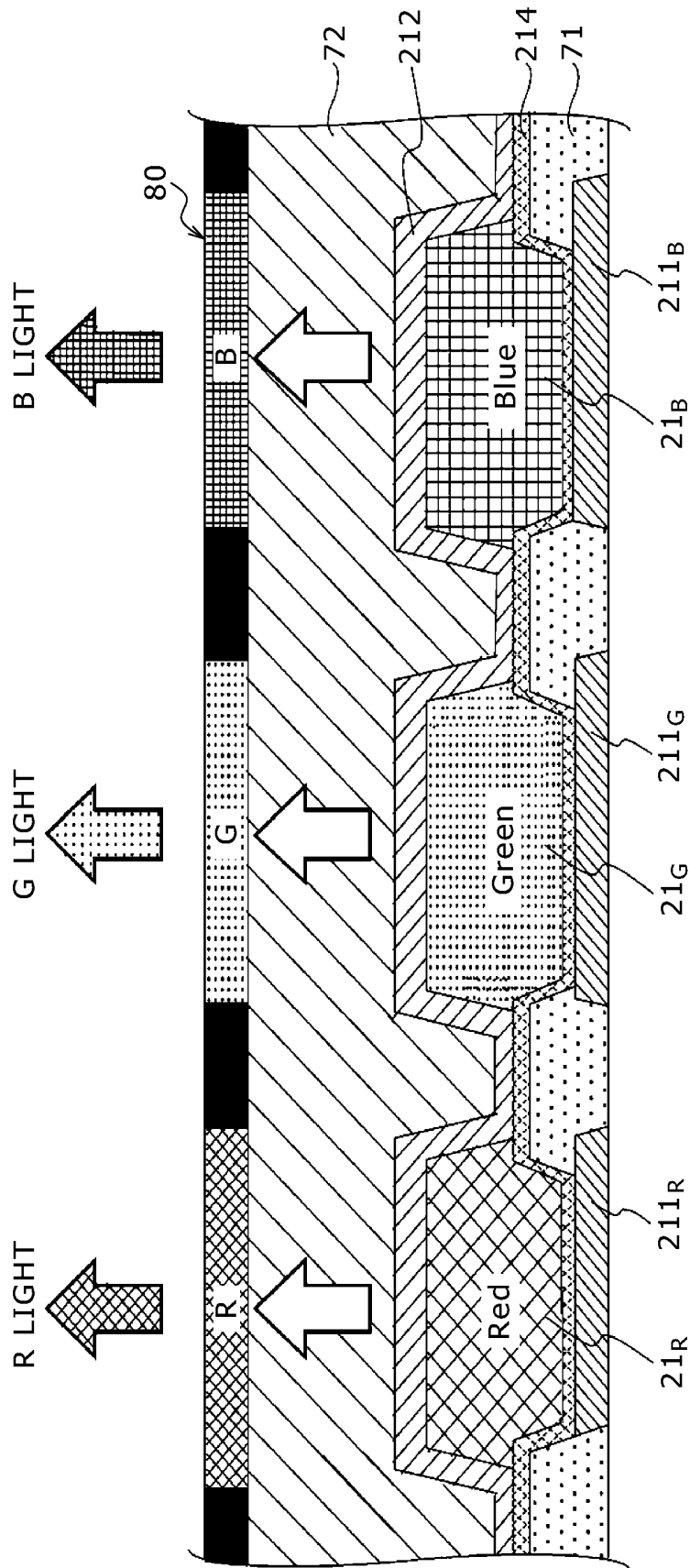

FIG. 15

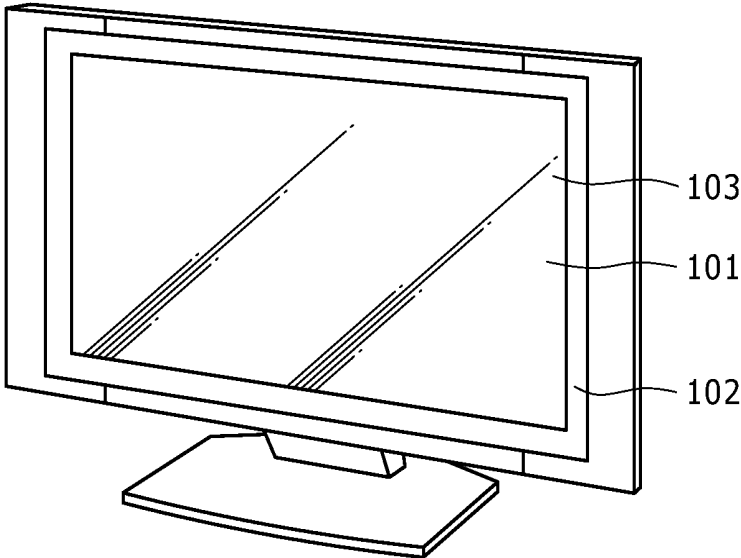

FIG. 16A

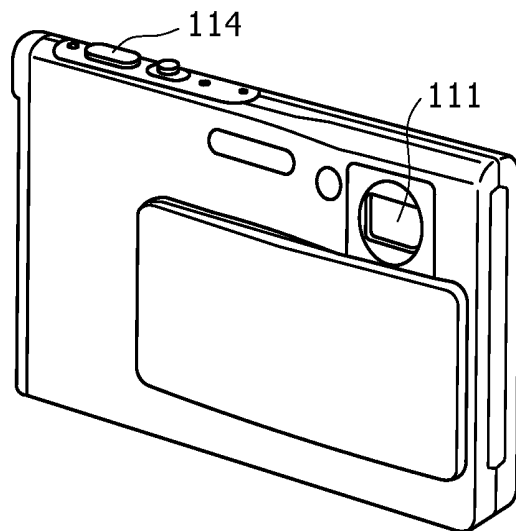

FIG. 16B

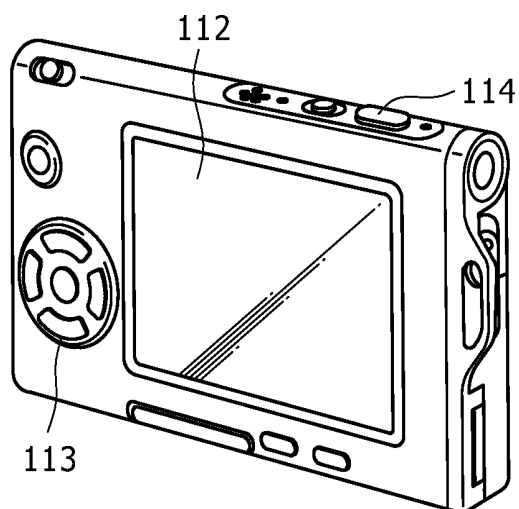

FIG. 17

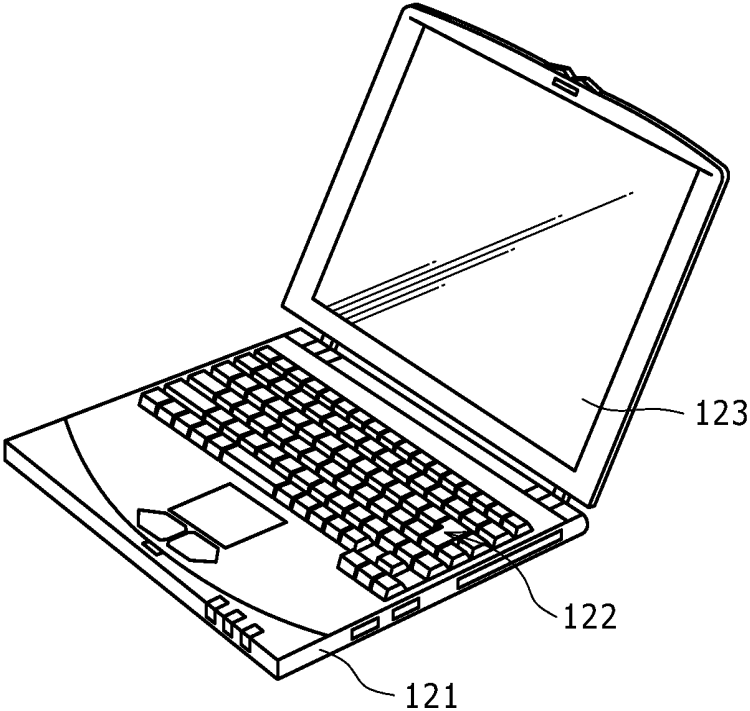

FIG. 18

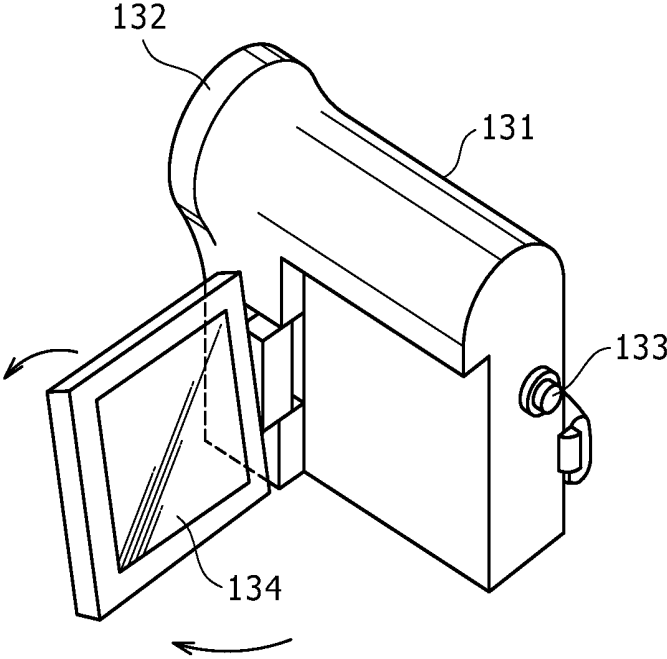

FIG. 19A

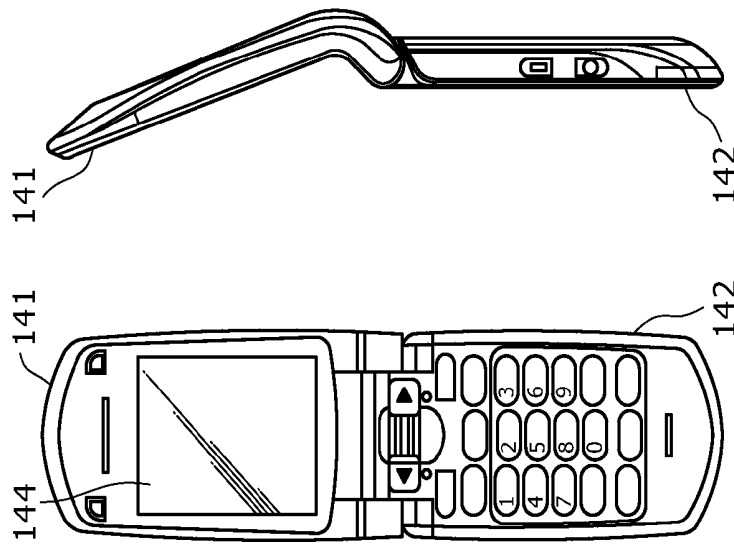

FIG. 19F

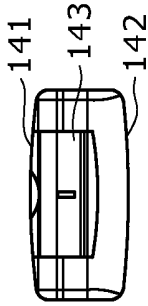

FIG. 19D

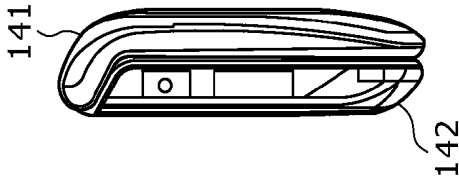

FIG. 19C

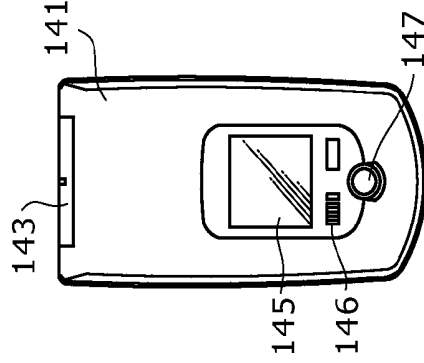

FIG. 19G

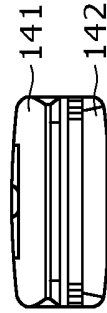
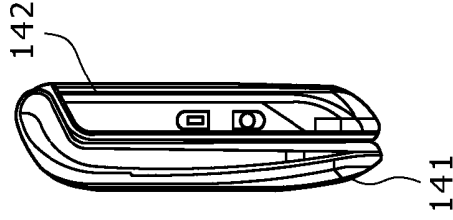

FIG. 19E



ORGANIC EL DISPLAY DEVICE AND ELECTRONIC APPARATUS

CROSS REFERENCE TO RELATED APPLICATIONS

[0001] This is a Continuation Application of U.S. patent application Ser. No. 13/305,308, filed Nov. 28, 2011, now U.S. Pat. No. 8,581,275, to be issued Nov. 12, 2013, which in turn claims priority from Japanese Application No. 2011-013049, filed on Jan. 25, 2011, the entire contents of which are incorporated herein by reference.

BACKGROUND

[0002] The present disclosure relates to an organic EL display device and electronic apparatus.

[0003] As one of planar type (flat panel type) display devices, there is a display device in which a so-called current-driven electrooptical element whose light emission luminance changes depending on the value of the current flowing through the element is used as a light emitter (light emitting element) of the pixel. As the current-driven electrooptical element, an organic EL element is known. The organic EL element utilizes electroluminescence (EL) of an organic material and uses a phenomenon in which an organic thin film emits light when an electric field is applied thereto.

[0004] The organic EL display device using the organic EL element as the light emitter of the pixel has the following features. Specifically, the organic EL element has low power consumption because it can be driven by an applied voltage of 10 V or lower. The organic EL element is a self-luminous element and therefore provides high image visibility compared with a liquid crystal display device. In addition, the organic EL element easily allows reduction in the weight and thickness of the display device because it does not require an illuminating component such as a backlight. Moreover, the organic EL element has a very high response speed of several microseconds and therefore a residual image in moving image displaying does not occur.

[0005] As the organic EL display device, a display device of a so-called RGB mask separate-application system obtained by separately applying organic EL materials of red (R), green (G), and blue (B) by evaporation with use of a mask is generally known. In contrast, there is a display device that is obtained without the RGB mask separate-application and is based on a system in which the respective color light beams of RGB are obtained by the combination of an organic EL element that emits white light (hereinafter, referred to as "white organic EL element") and a color filter for the purpose of increase in the size and definition of the display device (refer to e.g. Japanese Patent Laid-open No. 2003-123971).

SUMMARY

[0006] In the above-described organic EL display device based on the combination of the white organic EL element and the color filter, a common layer formed in common to the respective pixels exists. The existence of the common layer among the pixels causes the following problem. Specifically, leakage to a pixel that adjoins occurs through this common layer and the pixel that adjoins (hereinafter, referred to as "adjacent pixel") also emits light slightly due to this leakage. Therefore, the color reproducibility (color purity) is deteriorated.

[0007] This problem is not limited to the organic EL display device based on the combination of the white organic EL element and the color filter. Specifically, the same problem occurs also in e.g. an organic EL display device of the mask

separate-application system as long as a common layer exists among the pixels because leakage to the adjacent pixel occurs through this common layer.

[0008] There is a need for a technique to provide an organic EL display device capable of eliminating the problem of leakage to the adjacent pixel to achieve favorable color reproducibility (color purity) and electronic apparatus having this organic EL display device.

[0009] According to one embodiment of the present disclosure, there is provided an organic EL display device in which pixels each including an organic EL element formed by interposing an organic layer between an anode electrode and a cathode electrode are arranged in a matrix. The organic EL display device includes a common layer configured to be included in the organic EL element and be formed in the organic layer in common to the pixels, and a metal interconnect configured to surround the periphery of the anode electrode and be electrically connected to the organic layer. The potential of the metal interconnect is set to a potential lower than the potential of the anode electrode in the non-light-emission state of the organic EL element.

[0010] In the organic EL display device having the above-described configuration, the metal interconnect electrically connected to the organic layer is formed around the anode electrode. Due to this feature, even when a leakage current flows in the lateral direction through the common layer in the organic layer, this leakage current flows to the metal interconnect side. This can reduce the leakage current flowing into an adjacent pixel and thus suppress light emission in the adjacent pixel.

[0011] According to the embodiment of the present disclosure, light emission in the adjacent pixel can be suppressed even when a leakage current flows in the lateral direction through the common layer in the organic layer. Thus, favorable color reproducibility (color purity) can be achieved.

BRIEF DESCRIPTION OF THE DRAWINGS

[0012] FIG. 1 is a system configuration diagram showing the schematic configuration of an active-matrix organic EL display device to which one embodiment of the present disclosure is applied;

[0013] FIG. 2 is a circuit diagram showing one example of the specific circuit configuration of a pixel (pixel circuit);

[0014] FIG. 3 is a timing waveform diagram for explaining the basic circuit operation of the organic EL display device to which one embodiment of the present disclosure is applied;

[0015] FIGS. 4A to 4D are operation explanatory diagrams (first diagrams) of the basic circuit operation of the organic EL display device to which one embodiment of the present disclosure is applied;

[0016] FIGS. 5A to 5D are operation explanatory diagrams (second diagrams) of the basic circuit operation of the organic EL display device to which one embodiment of the present disclosure is applied;

[0017] FIGS. 6A and 6B are characteristic diagram FIG. 6A for explaining a problem attributed to variation in the threshold voltage V_{th} of a drive transistor and a characteristic diagram FIG. 6B for explaining a problem attributed to variation in the mobility μ of the drive transistor;

[0018] FIG. 7 is a sectional view showing one example of a pixel structure of a system of the combination of a white organic EL element and a color filter;

[0019] FIG. 8 is a sectional view of the major part showing one example of the structure of a white organic EL element having a typical tandem structure;

[0020] FIG. 9 is a circuit diagram showing the equivalent circuit of a display panel employing the system of the combination of the white organic EL element and the color filter;

[0021] FIG. 10 is a sectional view of the major part showing one example of a pixel structure including a white organic EL element having a tandem structure according to an embodiment of the present disclosure;

[0022] FIG. 11 is a planar pattern diagram showing anode electrodes and the periphery thereof;

[0023] FIG. 12 is an explanatory diagram about the operation and effect of the embodiment;

[0024] FIG. 13 is a circuit diagram showing the equivalent circuit of the display panel having the pixel structure according to the embodiment;

[0025] FIG. 14 is a sectional view of the major part showing one example of a pixel structure employing an RGB mask separate-application system;

[0026] FIG. 15 is a perspective view showing the appearance of a television set to which one embodiment of the present disclosure is applied;

[0027] FIGS. 16A and 16B are perspective views showing the appearance of a digital camera to which one embodiment of the present disclosure is applied: FIG. 16A is a perspective view of the front side and FIG. 16B is a perspective view of the back side;

[0028] FIG. 17 is a perspective view showing the appearance of a notebook personal computer to which one embodiment of the present disclosure is applied;

[0029] FIG. 18 is a perspective view showing the appearance of a video camcorder to which one embodiment of the present disclosure is applied; and

[0030] FIGS. 19A to 19G are appearance diagrams showing a cellular phone to which one embodiment of the present disclosure is applied: FIG. 19A is a front view of the opened state, FIG. 19B is a side view of the opened state, FIG. 19C is a front view of the closed state, FIG. 19D is a left side view, FIG. 19E is a right side view, FIG. 19F is a top view, and FIG. 19G is a bottom view.

DETAILED DESCRIPTION OF THE PREFERRED EMBODIMENT

[0031] A mode for carrying out the technique of the present disclosure (hereinafter, referred to as “embodiment”) will be described in detail below with reference to the drawings. The order of the description is as follows.

1. Organic EL Display Device to Which Embodiment of Present Disclosure Is Applied

1-1. System Configuration

1-2. Basic Circuit Operation

1-3. System of Combination of White Organic EL Element and Color Filter

1-4. Problem of Leakage Current Due to Existence of Common Layer

2. Description of Embodiment

2-1. Pixel Structure to Reduce Leakage Current

2-2. Operation and Effect of Embodiment

3. Modification Example

[0032] 4. application Examples (Electronic Apparatus)

1. Organic EL Display Device to which Embodiment of Present Disclosure is Applied

1-1. System Configuration

[0033] FIG. 1 is a system configuration diagram showing the schematic configuration of an active-matrix organic EL display device to which one embodiment of the present disclosure is applied.

[0034] The active-matrix organic EL display device is a display device that controls the current flowing through an organic EL element, which is a current-driven electrooptical element, by an active element provided in the same pixel as that of this organic EL element, e.g. an insulated-gate field effect transistor. As the insulated-gate field effect transistor, typically a thin film transistor (TFT) is used.

[0035] As shown in FIG. 1, an organic EL display device 10 according to the present application example has plural pixels 20 each including an organic EL element, a pixel array section 30 in which these pixels 20 are two-dimensionally arranged in a matrix, and a drive circuit section disposed around this pixel array section 30. The drive circuit section is composed of a write scan circuit 40, a power supply scan circuit 50, a signal output circuit 60, and so forth and drives the respective pixels 20 of the pixel array section 30.

[0036] If the organic EL display device 10 is for color displaying, one pixel serving as the unit to form a color image (unit pixel) is composed of plural sub-pixels and each of the sub-pixels is equivalent to the pixel 20 in FIG. 1. Specifically, in the display device for color displaying, one pixel is composed of e.g. three sub-pixels, a sub-pixel to emit red (R) light, a sub-pixel to emit green (G) light, and a sub-pixel to emit blue (B) light.

[0037] However, the configuration of one pixel is not limited to the combination of sub-pixels of three primary colors of RGB and it is also possible to configure one pixel by further adding a sub-pixel of one color or plural colors to the sub-pixels of three primary colors. Specifically, for example it is also possible to configure one pixel by adding a sub-pixel to emit white (W) light for luminance enhancement and to configure one pixel by adding at least one sub-pixel to emit complementary-color light for widening of the color reproduction range.

[0038] In the pixel array section 30, for the arrangement of the pixels 20 on m rows and n columns, scan lines 31₁ to 31_m and power supply lines 32₁ to 32_m are wired along the row direction (arrangement direction of the pixels on the pixel row) on each pixel row basis. Furthermore, for the arrangement of the pixels 20 on m rows and n columns, signal lines 33₁ to 33_n are wired along the column direction (arrangement direction of the pixels on the pixel column) on each pixel column basis.

[0039] Each of the scan lines 31₁ to 31_m is connected to the output terminal of the write scan circuit 40 for the corresponding row. Each of the power supply lines 32₁ to 32_m is connected to the output terminal of the power supply scan circuit 50 for the corresponding row. Each of the signal lines 33₁ to 33_n is connected to the output terminal of the signal output circuit 60 for the corresponding column.

[0040] The pixel array section 30 is normally formed on a transparent insulating substrate such as a glass substrate. Thus, the organic EL display device 10 has a planar type (flat type) panel structure. The drive circuits of the respective pixels 20 of the pixel array section 30 can be formed by using an amorphous silicon TFT or a low-temperature poly-silicon

TFT. If a low-temperature poly-silicon TFT is used, the write scan circuit 40, the power supply scan circuit 50, and the signal output circuit 60 can also be mounted on a display panel (substrate) 70, which forms the pixel array section 30, as shown in FIG. 1.

[0041] The write scan circuit 40 is configured with a shift register circuit that sequentially shifts (transfers) a start pulse sp in synchronization with a clock pulse ck , and so forth. In writing of the signal voltage of a video signal to the respective pixels 20 of the pixel array section 30, this write scan circuit 40 sequentially supplies a write scan signal WS (WS_1 to WS_m) to the scan line 31 (31_1 to 31_m) to thereby scan the respective pixels 20 of the pixel array section 30 in turn on a row-by-row basis (line-sequential scanning).

[0042] The power supply scan circuit 50 is configured with a shift register circuit that sequentially shifts the start pulse sp in synchronization with the clock pulse ck , and so forth. This power supply scan circuit 50 supplies, to the power supply line 32 (32_1 to 32_m), a supply potential DS (DS_1 to DS_m) capable of being switched between a first supply potential V_{ccp} and a second supply potential V_{imi} lower than the first supply potential V_{ccp} in synchronization with the line-sequential scanning by the write scan circuit 40. As described later, light-emission/non-light-emission of the pixel 20 is controlled by the switching of V_{ccp}/V_{imi} of the supply potential DS .

[0043] The signal output circuit 60 selectively outputs a reference voltage V_{ofs} and a signal voltage V_{sig} of the video signal corresponding to luminance information supplied from a signal supply source (not shown) (hereinafter, it will be often referred to simply as “signal voltage”). The reference voltage V_{ofs} is the potential serving as the basis of the signal voltage V_{sig} of the video signal (e.g. potential equivalent to the black level of the video signal) and is used in threshold correction processing to be described later.

[0044] The signal voltage V_{sig} /reference voltage V_{ofs} output from the signal output circuit 60 is written to the respective pixels 20 of the pixel array section 30 via the signal line 33 (33_1 to 33_n) in units of the pixel row selected by scanning by the write scan circuit 40. That is, the signal output circuit 60 employs the driving form of line-sequential writing to write the signal voltage V_{sig} in units of the row (line).

(Pixel Circuit)

[0045] FIG. 2 is a circuit diagram showing one example of the specific circuit configuration of the pixel (pixel circuit) 20. The light emitter of the pixel 20 is formed of an organic EL element 21, which is a current-driven electrooptical element whose light emission luminance changes depending on the value of the current flowing through the element.

[0046] As shown in FIG. 2, the pixel 20 is configured with the organic EL element 21 and the drive circuit that drives the organic EL element 21 by applying a current to the organic EL element 21. The cathode electrode of the organic EL element 21 is connected to a common power supply line 34 wired in common to all pixels 20 (so-called blanket interconnect).

[0047] The drive circuit to drive the organic EL element 21 has a drive transistor 22, a write transistor 23, hold capacitance 24, and auxiliary capacitance 25. N-channel TFTs can be used as the drive transistor 22 and the write transistor 23. However, this combination of the conductivity type of the drive transistor 22 and the write transistor 23 is merely one example and the combination of the conductivity type is not limited thereto.

[0048] One electrode (source/drain electrode) of the drive transistor 22 is connected to the power supply line 32 (32_1 to 32_m) and the other electrode (drain/source electrode) is connected to the anode electrode of the organic EL element 21.

[0049] One electrode (source/drain electrode) of the write transistor 23 is connected to the signal line 33 (33_1 to 33_n) and the other electrode (drain/source electrode) is connected to the gate electrode of the drive transistor 22. The gate electrode of the write transistor 23 is connected to the scan line 31 (31_1 to 31_m).

[0050] In the drive transistor 22 and the write transistor 23, one electrode refers to the metal interconnect electrically connected to the source/drain region and the other electrode refers to the metal interconnect electrically connected to the drain/source region. Depending on the potential relationship between one electrode and the other electrode, possibly one electrode serves as either the source electrode or the drain electrode and the other electrode serves as either the drain electrode or the source electrode.

[0051] One electrode of the hold capacitance 24 is connected to the gate electrode of the drive transistor 22 and the other electrode is connected to the other electrode of the drive transistor 22 and the anode electrode of the organic EL element 21.

[0052] One electrode of the auxiliary capacitance 25 is connected to the anode electrode of the organic EL element 21 and the other electrode is connected to the common power supply line 34. This auxiliary capacitance 25 is provided according to need in order to compensate for insufficiency of the capacitance of the organic EL element 21 and enhance the gain of writing of the video signal to the hold capacitance 24. That is, the auxiliary capacitance 25 is not an essential constituent element and can be omitted if the equivalent capacitance of the organic EL element 21 is sufficiently high.

[0053] In this example, the other electrode of the auxiliary capacitance 25 is connected to the common power supply line 34. However, the connection subject of the other electrode is not limited to the common power supply line 34 as long as the connection subject is a node at a fixed potential. Connecting the other electrode of the auxiliary capacitance 25 to the node of a fixed potential allows achievement of the desired purposes of compensating for insufficiency of the capacitance of the organic EL element 21 and enhancing the gain of writing of the video signal to the hold capacitance 24.

[0054] In the pixel 20 having the above-described configuration, the write transistor 23 becomes the conductive state in response to the High-active write scan signal WS applied from the write scan circuit 40 to the gate electrode via the scan line 31. Thereby, the write transistor 23 performs sampling of the signal voltage V_{sig} of the video signal corresponding to luminance information or the reference voltage V_{ofs} , supplied from the signal output circuit 60 via the signal line 33, and writes it in the pixel 20. This written signal voltage V_{sig} or reference voltage V_{ofs} is applied to the gate electrode of the drive transistor 22 and held in the hold capacitance 24.

[0055] When the supply potential DS of the power supply line 32 (32_1 to 32_m) is the first supply potential V_{ccp} , one electrode of the drive transistor 22 serves as the drain electrode and the other electrode serves as the source electrode and the drive transistor 22 operates in the saturation region. Thereby, the drive transistor 22 receives supply of a current from the power supply line 32 and drives light emission of the organic EL element 21 based on current driving. Specifically, the drive transistor 22 operates in the saturation region to

thereby supply, to the organic EL element **21**, a drive current having the current value depending on the voltage value of the signal voltage V_{sig} held in the hold capacitance **24** and make the organic EL element **21** emit light by current driving thereof.

[0056] When the supply potential DS is switched from the first supply potential V_{ccp} to the second supply potential V_{imi} , one electrode of the drive transistor **22** serves as the source electrode and the other electrode serves as the drain electrode and the drive transistor **22** operates as a switching transistor. Thereby, the drive transistor **22** stops the supply of the drive current to the organic EL element **21** and turns the organic EL element **21** to the non-light-emission state. That is, the drive transistor **22** has also a function as a transistor to control light-emission/non-light-emission of the organic EL element **21**.

[0057] This switching operation of the drive transistor **22** can set the period during which the organic EL element **21** is in the non-light-emission state (non-light-emission period) and control the ratio between the light-emission period and the non-light-emission period of the organic EL element **21** (duty). By this duty control, the residual image blur accompanying the light emission of the pixel over one display frame period can be reduced and thus particularly the image quality of moving images can be made more excellent.

[0058] Of the first and second supply potentials V_{ccp} and V_{imi} selectively supplied from the power supply scan circuit **50** via the power supply line **32**, the first supply potential V_{ccp} is a supply potential for supplying the drive current for light emission driving of the organic EL element **21** to the drive transistor **22**. The second supply potential V_{imi} is a supply potential for applying a reverse bias to the organic EL element **21**. This second supply potential V_{imi} is set to a potential lower than the reference voltage V_{ofs} , e.g. a potential lower than $V_{ofs}-V_{th}$ when the threshold voltage of the drive transistor **22** is V_{th} , preferably to a potential sufficiently lower than $V_{ofs}-V_{th}$.

1-2. Basic Circuit Operation

[0059] The basic circuit operation of the organic EL display device **10** having the above-described configuration will be described below based on a timing waveform diagram of FIG. 3 with use of operation explanatory diagrams of FIGS. 4A to 5D. In the operation explanatory diagrams of FIGS. 4A to 5D, the write transistor **23** is shown by a switch symbol for simplification of the drawings. Furthermore, the auxiliary capacitance **25** of the organic EL element **21** is also shown.

[0060] The timing waveform diagram of FIG. 3 shows change in each of the potential (write scan signal) WS of the scan line **31**, the potential (supply potential) DS of the power supply line **32**, the potential (V_{sig}/V_{ofs}) of the signal line **33**, and the gate potential V_g and the source potential V_s of the drive transistor **22**.

(Light-Emission Period of Previous Display Frame)

[0061] In the timing waveform diagram of FIG. 3, the period before a time t_{11} is the light-emission period of the organic EL element **21** in the previous display frame. In this light-emission period of the previous display frame, the potential DS of the power supply line **32** is the first supply potential (hereinafter, referred to as "higher potential") V_{ccp} and the write transistor **23** is in the non-conductive state.

[0062] The drive transistor **22** is so designed as to operate in the saturation region at this time. Thus, as shown in FIG. 4A, the drive current (drain-source current) I_{ds} depending on the gate-source voltage V_{gs} of the drive transistor **22** is supplied from the power supply line **32** to the organic EL element **21** via the drive transistor **22**. Therefore, the organic EL element **21** emits light with the luminance depending on the current value of the drive current I_{ds} .

(Threshold Correction Preparation Period)

[0063] At the time t_{11} , a new display frame (present display frame) of the line-sequential scanning starts. At this time, as shown in FIG. 4B, the potential DS of the power supply line **32** is switched from the higher potential V_{ccp} to the second supply potential (hereinafter, referred to as "lower potential") V_{imi} sufficiently lower than $V_{ofs}-V_{th}$ with respect to the reference voltage V_{ofs} of the signal line **33**.

[0064] Here, the threshold voltage of the organic EL element **21** is defined as V_{the1} and the potential of the common power supply line **34** (cathode potential) is defined as V_{cath} . If the lower potential V_{imi} is so set as to satisfy a relationship of $V_{imi} < V_{the1} + V_{cath}$, the organic EL element **21** becomes the reverse-biased state and stops its light emission because the source potential V_s of the drive transistor **22** becomes almost equal to the lower potential V_{imi} .

[0065] Next, the potential WS of the scan line **31** is shifted from the lower-potential side to the higher-potential side at a time t_{12} . Thereby, the write transistor **23** becomes the conductive state as shown in FIG. 4C. At this time, the reference voltage V_{ofs} is supplied from the signal output circuit **60** to the signal line **33** and therefore the gate potential V_g of the drive transistor **22** becomes the reference voltage V_{ofs} . The source potential V_s of the drive transistor **22** is a potential sufficiently lower than the reference voltage V_{ofs} , i.e. the lower potential V_{imi} .

[0066] At this time, the gate-source voltage V_{gs} of the drive transistor **22** is $V_{ofs}-V_{imi}$. Unless $V_{ofs}-V_{imi}$ is higher than the threshold voltage V_{th} of the drive transistor **22**, the threshold correction processing to be described later cannot be executed. Therefore, a potential relationship of $V_{ofs}-V_{imi} > V_{th}$ should be set.

[0067] This processing of initializing the potentials by fixing the gate potential V_g of the drive transistor **22** to the reference voltage V_{ofs} and fixing (settling) the source potential V_s to the lower potential V_{imi} in this manner is preparation (threshold correction preparation) processing preceding the threshold correction processing (threshold correction operation) to be described later. Therefore, the reference voltage V_{ofs} and the lower potential V_{imi} serve as the initialization potential for the gate potential V_g and the source potential V_s , respectively, of the drive transistor **22**.

(Threshold Correction Period)

[0068] Next, at a time t_{13} , the potential DS of the power supply line **32** is switched from the lower potential V_{imi} to the higher potential V_{ccp} as shown in FIG. 4D. Thereupon, the threshold correction processing is started, with the gate potential V_g of the drive transistor **22** kept at the reference voltage V_{ofs} . Specifically, the source potential V_s of the drive transistor **22** starts to rise toward the potential obtained by subtracting the threshold voltage V_{th} of the drive transistor **22** from the gate potential V_g .

[0069] Here, for convenience, the processing in which the initialization potential V_{ofs} for the gate potential V_g of the drive transistor 22 is used as the basis and the source potential V_s is changed toward the potential obtained by subtracting the threshold voltage V_{th} of the drive transistor 22 from this initialization potential V_{ofs} is called the threshold correction processing. Along with the progression of this threshold correction processing, the gate-source voltage V_{gs} of the drive transistor 22 converges on the threshold voltage V_{th} of the drive transistor 22 in due course. The voltage equivalent to this threshold voltage V_{th} is held in the hold capacitance 24.

[0070] In order that the current may flow exclusively to the hold capacitance 24 and be prevented from flowing to the organic EL element 21 in the period of the threshold correction processing (threshold correction period), the potential V_{cath} of the common power supply line 34 is so set that the organic EL element 21 is kept at the cut-off state in this period.

[0071] Next, the potential WS of the scan line 31 is shifted to the lower-potential side at a time t_{14} . Thereby, the write transistor 23 becomes the non-conductive state as shown in FIG. 5A. At this time, the gate electrode of the drive transistor 22 is electrically isolated from the signal line 33 to thereby become the floating state. However, because the gate-source voltage V_{gs} is equal to the threshold voltage V_{th} of the drive transistor 22, the drive transistor 22 is in the cut-off state. Therefore, the drain-source current I_{ds} does not flow through the drive transistor 22.

(Signal Writing and Mobility Correction Period)

[0072] Next, at a time t_{15} , the potential of the signal line 33 is switched from the reference voltage V_{ofs} to the signal voltage V_{sig} of the video signal as shown in FIG. 5B. Subsequently, at a time t_{16} , the potential WS of the scan line 31 is shifted to the higher-potential side. Thereby, as shown in FIG. 5C, the write transistor 23 becomes the conductive state to perform sampling of the signal voltage V_{sig} of the video signal and write it in the pixel 20.

[0073] Due to this writing of the signal voltage V_{sig} by the write transistor 23, the gate potential V_g of the drive transistor 22 becomes the signal voltage V_{sig} . In driving of the drive transistor 22 based on the signal voltage V_{sig} of the video signal, the threshold voltage V_{th} of the drive transistor 22 is canceled out by the voltage equivalent to the threshold voltage V_{th} held in the hold capacitance 24. Details of the principle of this threshold cancel will be described later.

[0074] At this time, the organic EL element 21 is in the cut-off state (high-impedance state). Therefore, the current (drain-source current I_{ds}) flowing from the power supply line 32 to the drive transistor 22 depending on the signal voltage V_{sig} of the video signal flows into the equivalent capacitance of the organic EL element 21 and the auxiliary capacitance 25. Thereby, the charge of the equivalent capacitance of the organic EL element 21 and the auxiliary capacitance 25 is started.

[0075] Due to the charge of the equivalent capacitance of the organic EL element 21 and the auxiliary capacitance 25, the source potential V_s of the drive transistor 22 rises over time. At this time, variation in the threshold voltage V_{th} of the drive transistor 22 from pixel to pixel has been already canceled and the drain-source current I_{ds} of the drive transistor 22 depends on the mobility μ of the drive transistor 22. The

mobility μ of the drive transistor 22 is the mobility of the semiconductor thin film configuring the channel of the drive transistor 22.

[0076] Here, suppose that the ratio of the held voltage V_{gs} of the hold capacitance 24 to the signal voltage V_{sig} of the video signal, i.e. a writing gain G , is one (ideal value). In this case, due to the rise of the source potential V_s of the drive transistor 22 to a potential of $V_{ofs} - V_{th} + \Delta V$, the gate-source voltage V_{gs} of the drive transistor 22 becomes $V_{sig} - V_{ofs} + V_{th} - \Delta V$.

[0077] Specifically, the rise component ΔV of the source potential V_s of the drive transistor 22 acts in such a manner as to be subtracted from the voltage ($V_{sig} - V_{ofs} + V_{th}$) held in the hold capacitance 24, i.e. as to discharge the charge accumulated in the hold capacitance 24. In other words, the rise component ΔV of the source potential V_s means negative feedback to the hold capacitance 24. Therefore, the rise component ΔV of the source potential V_s is equivalent to the feedback amount of the negative feedback.

[0078] By applying negative feedback to the gate-source voltage V_{gs} with the feedback amount ΔV depending on the drain-source current I_{ds} flowing through the drive transistor 22 in this manner, the dependence of the drain-source current I_{ds} of the drive transistor 22 on the mobility μ can be canceled. This cancel processing is the mobility correction processing to correct variation in the mobility μ of the drive transistor 22 from pixel to pixel.

[0079] Specifically, when the signal amplitude V_{in} ($=V_{sig} - V_{ofs}$) of the video signal written to the gate electrode of the drive transistor 22 is higher, the drain-source current I_{ds} is larger and thus the absolute value of the feedback amount ΔV of the negative feedback is also larger. Therefore, the mobility correction processing depending on the light emission luminance level is executed.

[0080] If the signal amplitude V_{in} of the video signal is set constant, when the mobility μ of the drive transistor 22 is higher, the absolute value of the feedback amount ΔV of the negative feedback is also larger. Thus, variation in the mobility μ from pixel to pixel can be eliminated. Therefore, the feedback amount ΔV of the negative feedback can be regarded also as the correction amount of the mobility correction processing. Details of the principle of the mobility correction will be described later.

(Light-Emission Period)

[0081] Next, the potential WS of the scan line 31 is shifted to the lower-potential side at a time t_{17} . Thereby, the write transistor 23 becomes the non-conductive state as shown in FIG. 5D. Thus, the gate electrode of the drive transistor 22 is electrically isolated from the signal line 33 and therefore becomes the floating state.

[0082] When the gate electrode of the drive transistor 22 is in the floating state, the gate potential V_g also changes in conjunction with change in the source potential V_s of the drive transistor 22 because the hold capacitance 24 is connected between the gate and source of the drive transistor 22. The operation of this change in the gate potential V_g of the drive transistor 22 in conjunction with the change in the source potential V_s is bootstrap operation by the hold capacitance 24.

[0083] The gate electrode of the drive transistor 22 becomes the floating state and simultaneously the drain-source current I_{ds} of the drive transistor 22 starts to flow to the organic EL element 21. Thereby, the anode potential of the organic EL element 21 rises depending on this current I_{ds} .

[0084] When the anode potential of the organic EL element **21** surpasses $V_{th1} + V_{cath}$, the drive current starts to flow to the organic EL element **21** and thus the organic EL element **21** starts light emission. The rise of the anode potential of the organic EL element **21** is nothing more or less than the rise of the source potential V_s of the drive transistor **22**. When the source potential V_s of the drive transistor **22** rises, the gate potential V_g of the drive transistor **22** also rises in conjunction with this source potential rise due to the bootstrap operation of the hold capacitance **24**.

[0085] At this time, the amount of rise of the gate potential V_g is equal to that of rise of the source potential V_s if it is assumed that the bootstrap gain is one (ideal value). Therefore, during the light-emission period, the gate-source voltage V_{gs} of the drive transistor **22** is kept constant at $V_{sig} - V_{ofs} + V_{th} - \Delta V$. At a time t_{18} , the potential of the signal line **33** is switched from the signal voltage V_{sig} of the video signal to the reference voltage V_{ofs} .

[0086] In the above-described series of circuit operation, the respective processing operations of the threshold correction preparation, the threshold correction, the writing of the signal voltage V_{sig} (signal writing), and the mobility correction are carried out in one horizontal scanning period (1H). Furthermore, the respective processing operations of the signal writing and the mobility correction are carried out in parallel in the period from the time t_{16} to the time t_{17} .

[Divided Threshold Correction]

[0087] The above description is made by taking as an example the case of employing the driving method in which the threshold correction processing is executed only once. However, this driving method is merely one example and the driving method is not limited thereto. For example, it is also possible to employ a driving method in which so-called divided threshold correction is performed, i.e. the threshold correction processing is executed plural times in a divided manner over plural horizontal scanning periods preceding the 1H period in which the threshold correction processing is executed together with the mobility correction and signal writing processing in addition to this 1H period.

[0088] If this driving method with the divided threshold correction is employed, a sufficient time can be ensured as the threshold correction period over plural horizontal scanning periods even if the time allocated as one horizontal scanning period becomes short due to increase in the number of pixels in association with enhancement in the definition. Therefore, even if the time allocated as one horizontal scanning period becomes short, the threshold correction processing can be surely executed because a sufficient time can be ensured as the threshold correction period.

[Principle of Threshold Cancel]

[0089] The principle of the threshold cancel (i.e. threshold correction) for the drive transistor **22** will be described below. The drive transistor **22** is so designed as to operate in the saturation region and therefore operates as a constant current source. Thus, the constant drain-source current (drive current) I_{ds} given by the following equation (1) is supplied from the drive transistor **22** to the organic EL element **21**.

$$I_{ds} = (\frac{1}{2}) \cdot \mu (W/L) C_{ox} (V_{gs} - V_{th})^2 \quad (1)$$

[0090] In this equation, W is the channel width of the drive transistor **22**. L is the channel length. C_{ox} is the gate capacitance per unit area.

[0091] FIG. 6A shows the characteristic of drain-source current I_{ds} vs. gate-source voltage V_{gs} of the drive transistor **22**. As shown in the characteristic diagram of FIG. 6A, unless the cancel processing (correction processing) for variation in the threshold voltage V_{th} of the drive transistor **22** from pixel to pixel is executed, the drain-source current I_{ds} corresponding to the gate-source voltage V_{gs} is I_{ds1} when the threshold voltage V_{th} is V_{th1} .

[0092] On the other hand, when the threshold voltage V_{th} is V_{th2} ($V_{th2} > V_{th1}$), the drain-source current I_{ds} corresponding to the same gate-source voltage V_{gs} is I_{ds2} ($I_{ds2} < I_{ds1}$). That is, if the threshold voltage V_{th} of the drive transistor **22** varies, the drain-source current I_{ds} varies even when the gate-source voltage V_{gs} is constant.

[0093] In the pixel (pixel circuit) **20** having the above-described configuration, the gate-source voltage V_{gs} of the drive transistor **22** in light emission is $V_{sig} - V_{ofs} + V_{th} - \Delta V$ as described above. Therefore, if this voltage V_{gs} is substituted in equation (1), the drain-source current I_{ds} is represented by the following equation (2).

$$I_{ds} = (\frac{1}{2}) \cdot \mu (W/L) C_{ox} (V_{sig} - V_{ofs} - \Delta V)^2 \quad (2)$$

[0094] That is, the term of the threshold voltage V_{th} of the drive transistor **22** is canceled, so that the drain-source current I_{ds} supplied from the drive transistor **22** to the organic EL element **21** does not depend on the threshold voltage V_{th} of the drive transistor **22**. As a result, even when the threshold voltage V_{th} of the drive transistor **22** varies from pixel to pixel due to variation in the manufacturing process of the drive transistor **22**, change over time, and so forth, the drain-source current I_{ds} does not vary and thus the light emission luminance of the organic EL element **21** can be kept constant.

[Principle of Mobility Correction]

[0095] The principle of the mobility correction for the drive transistor **22** will be described below. FIG. 6B shows characteristic curves with comparison between pixel A in which the mobility μ of the drive transistor **22** is relatively higher and pixel B in which the mobility μ of the drive transistor **22** is relatively lower. If the drive transistor **22** is configured by a poly-silicon thin film transistor or the like, inevitably the mobility μ varies among the pixels like pixel A and pixel B.

[0096] A consideration will be made below about the case in which the mobility μ varies between pixels A and B and e.g. the signal amplitude V_{in} ($=V_{sig} - V_{ofs}$) at the same level is written to the gate electrode of the drive transistor **22** of both pixels A and B. In this case, if correction of the mobility μ is not performed at all, large difference arises between a drain-source current I_{ds1} flowing in pixel A having the higher mobility μ and a drain-source current I_{ds2} flowing in pixel B having the lower mobility μ . If large difference in the drain-source current I_{ds} arises among the pixels attributed to variation in the mobility μ among the pixels in this manner, the uniformity (evenness) of the screen is spoiled.

[0097] As is apparent from the transistor characteristic expression of the above-described equation (1), the higher mobility μ yields the larger drain-source current I_{ds} . Therefore, the higher the mobility μ is, the larger the feedback amount ΔV of negative feedback is. As shown in FIG. 6B, a feedback amount ΔV_1 in pixel A having the higher mobility μ is larger than a feedback amount ΔV_2 in pixel B having the lower mobility μ .

[0098] So, if negative feedback is applied to the gate-source voltage V_{gs} with the feedback amount ΔV depending on the

drain-source current I_{ds} of the drive transistor **22** by the mobility correction processing, the extent of this negative feedback is larger when the mobility μ is higher. As a result, the variation in the mobility μ from pixel to pixel can be suppressed.

[0099] Specifically, when correction with the feedback amount ΔV_1 is performed in pixel A having the higher mobility μ , the drain-source current I_{ds} greatly drops from I_{ds1}' to I_{ds1} . In contrast, the feedback amount ΔV_2 in pixel B having the lower mobility μ is small. Therefore, the drain-source current I_{ds} does not drop so greatly, i.e. the drop is from I_{ds2}' to I_{ds2} . As a result, the drain-source current I_{ds1} of pixel A is almost equal to the drain-source current I_{ds2} of pixel B, so that the variation in the mobility μ from pixel to pixel is corrected.

[0100] In conclusion, when there are pixel A and pixel B having the different mobility μ , the feedback amount ΔV_1 in pixel A having the higher mobility μ is larger than the feedback amount ΔV_2 in pixel B having the lower mobility μ . That is, the feedback amount ΔV is larger and the amount of decrease in the drain-source current I_{ds} is larger in the pixel having the higher mobility μ .

[0101] Therefore, by applying negative feedback to the gate-source voltage V_{gs} with the feedback amount ΔV depending on the drain-source current I_{ds} of the drive transistor **22**, the current value of the drain-source current I_{ds} of the pixels having the different mobility μ is made uniform. As a result, variation in the mobility μ from pixel to pixel can be corrected. That is, the mobility correction processing is the processing of applying negative feedback to the gate-source voltage V_{gs} of the drive transistor **22**, i.e. the hold capacitance **24**, with the feedback amount (correction amount) ΔV depending on the current (drain-source current I_{ds}) flowing through the drive transistor **22**.

1-3. System of Combination of White Organic EL Element and Color Filter

[0102] In the organic EL display device **10** according to the above-described present application example, the RGB mask separate-application system is not employed and a system in which the respective color light beams of RGB are obtained by the combination of a white organic EL element 21_w and a color filter **80** as shown in FIG. 7 is employed. The RGB mask separate-application system is a system in which organic EL materials of RGB are separately applied by evaporation with use of a mask. The system of the combination of the white organic EL element 21_w and the color filter **80** is suitable for increase in the size and definition of the display panel **70**.

(White Organic EL Element Having Tandem Structure)

[0103] As the white organic EL element 21_w , an organic EL element having a tandem structure is widely known. For example, the tandem structure is formed by coupling (stacking) plural units (light emitting units) of an organic layer including the respective light emitting layers of RGB in a series (tandem) manner with the intermediary of connecting layers. From the white organic EL element having this tandem structure, white light is obtained through superposition of the light emission of the respective light emitting units of RGB.

[0104] FIG. 8 is a sectional view of the major part showing one example of the structure of the white organic EL element having a typical tandem structure. Here, a three-stage tandem structure is taken as one example and a basic structure is shown in a simplified manner for simplification of the dia-

gram. Furthermore, FIG. 8 shows the pixel structure of two sub-pixels of RG among three sub-pixels of RGB.

[0105] Referring to FIG. 8, anode electrodes **211** (211_R , 211_G , 211_B) are provided on a pixel-by-pixel basis at the bottom of a recess 71_A of a window insulating film **71**. An organic layer **213** is provided in common to all pixels between the anode electrodes **211** and a cathode electrode **212** provided in common to all pixels, so that the white organic EL element 21_w is configured. An interlayer insulating film **72** is stacked on the cathode electrode **212** and the color filter **80** is formed on this interlayer insulating film **72** in an on-chip form (on-chip color filter).

[0106] In the white organic EL element 21_w , the organic layer **213** is formed by sequentially depositing a charge injection layer **214**, a light emitting layer 215_R of R, a connecting layer **216**, a light emitting layer 215_G of G, a connecting layer **217**, and a light emitting layer 215_B of B over the anode electrodes **211** in common to all pixels, as one example. Under current driving by the drive transistor **22** in FIG. 2, a current flows from the drive transistor **22** to the organic layer **213** via the anode electrode **211**. Thereby, recombination of electrons and holes occurs in the respective light emitting layers 215_R , 215_G , and 215_B in the organic layer **213**. In this recombination, light emission occurs.

[0107] At this time, the light emission colors of the respective light emitting layers 215_R , 215_G , and 215_B of R, G, and B are superimposed on (combined with) each other to become white light. The white light emitted from the white organic EL element 21_w on a pixel-by-pixel basis is transmitted through the color filter **80**. By combining the white organic EL element 21_w with the color filter **80** in this manner, the respective color light beams of R, G, and B can be obtained from the white light.

1-4. Problem of Leakage Current Due to Existence of Common Layer

[0108] In the organic EL display device **10** formed by disposing the pixels (sub-pixels) including the white organic EL element 21_w having the above-described tandem structure, a common layer formed in common to the respective pixels exists. Specifically, as is apparent from FIG. 8 particularly, the charge injection layer **214**, the connecting layer **216**, and the connecting layer **217** are the common layers formed in common to the respective pixels.

[0109] A consideration will be made about a problem of leakage current due to the existence of the common layer (leakage current flowing through the common layer) by taking as an example the case in which only the pixel (sub-pixel) of R emits light in FIG. 8. FIG. 9 shows the equivalent circuit of the display panel **70** in the case of employing the system of the combination of the white organic EL element 21_w and the color filter **80**.

[0110] In the display panel **70** employing the system of the combination of the white organic EL element 21_w and the color filter **80**, leakage in the lateral direction occurs in layers (common layers) having comparatively-low impedance, such as the charge injection layer **214** and the connecting layers **216** and **217**. The lateral direction refers to the flow direction of the leakage current when the flow direction of the current flowing in the white organic EL element 21_w is defined as the vertical direction. Due to this leakage current, an area outside the anode electrode **211** also emits light.

[0111] No problem is caused if the distance between adjacent pixels is sufficiently long (separate). However, if the

distance between adjacent pixels is short and the leakage current flows into the adjacent pixel, the area of light emission accompanying the leakage current ranges to the adjacent pixel. As a result, the adjacent pixel also emits light. In FIG. 8, the size of the arrow representing the light emission color conceptually indicates the intensity of this light. In the case of the present example, the pixel of G adjacent to the pixel of R that should emit light originally also emits light. This deteriorates the color reproducibility (color purity). Although the light emitting layers 215_R , 215_G , and 215_B are also common layers, generally they are free from the problem of the leakage because the impedance thereof is high compared with the charge injection layer 214 , the connecting layers 216 and 217 , and so forth.

2. Description of Embodiment

[0112] In the present embodiment, in order to solve the problem of the leakage current due to the existence of the common layer in an organic EL display device including at least one common layer formed in an organic layer in common to the pixels, a metal interconnect electrically connected to the organic layer is so formed as to surround the periphery of the anode electrode. Furthermore, the present embodiment employs a configuration in which the potential of this metal interconnect is set to a potential lower than the potential of the anode electrode in the non-light-emission state of the organic EL element.

[0113] Due to the characteristic that the metal interconnect electrically connected to the organic layer is formed around the anode electrode, even when a leakage current flows in the lateral direction through the common layer in the organic layer, this leakage current flows to the metal interconnect side. This can reduce the leakage current flowing into the adjacent pixel and thus can suppress light emission in the adjacent pixel. As a result, favorable color reproducibility (color purity) can be achieved.

2-1. Pixel Structure to Reduce Leakage Current

[0114] A pixel structure to reduce the leakage current flowing through the common layer in the organic layer will be specifically described below.

[0115] FIG. 10 is a sectional view of the major part showing one example of the pixel structure including a white organic EL element having a tandem structure according to the embodiment. In FIG. 10, the part equivalent to that in FIG. 8 is given the same numeral. FIG. 11 shows a planar pattern diagram of the anode electrodes and the periphery thereof. Here, a three-stage tandem structure is taken as one example and a basic structure is shown in a simplified manner for simplification of the diagram. Furthermore, FIG. 10 shows the pixel structure of two sub-pixels of RG among three sub-pixels of RGB.

[0116] Regarding the basic structure, the white organic EL element having the tandem structure according to the present embodiment is the same as the above-described white organic EL element having the typical tandem structure. Specifically, as shown in FIG. 10, the anode electrodes 211 (211_R , 211_G , 211_B) are provided on a pixel-by-pixel basis at the bottom of the recess 71_A of the window insulating film 71 . The organic layer 213 is provided in common to all pixels between the anode electrodes 211 and the cathode electrode 212 provided in common to all pixels, so that the white organic EL element 21_W is configured.

[0117] In the white organic EL element 21_W , the organic layer 213 is formed by sequentially depositing the charge injection layer 214 , the light emitting layer 215_R of R, the connecting layer 216 , the light emitting layer 215_G of G, the connecting layer 217 , and the light emitting layer 215_B of B over the anode electrodes 211 in common to all pixels, as one example. The interlayer insulating film 72 is stacked on the cathode electrode 212 and the color filter 80 is formed on this interlayer insulating film 72 in an on-chip form.

[0118] In the pixel structure including the white organic EL element 21_W having the tandem structure with the above-described configuration, the present embodiment has the following features. First, a metal interconnect 90 is so formed as to surround the periphery of the anode electrodes 211 (211_R , 211_G , 211_B) formed on a pixel-by-pixel basis, specifically at the same layer as that of the anode electrodes 211 .

[0119] Furthermore, to this metal interconnect 90 , a potential lower than the potential of the anode electrode 211 in the non-light-emission state of the white organic EL element 21_W , e.g. the potential of the cathode electrode 212 (cathode potential V_{cath}), is given. Using the cathode potential V_{cath} as the potential of the metal interconnect 90 provides an advantage that the potential used exclusively for the metal interconnect 90 does not need to be prepared.

[0120] It is preferable to use, as the material of the metal interconnect 90 , the same material as that of the anode electrode 211 , e.g. an interconnect material such as aluminum (Al) or silver (Ag). This is because using the same material as that of the anode electrode 211 as the material of the metal interconnect 90 provides an advantage that the metal interconnect 90 can be formed in the same step as that of the anode electrode 211 and thus the number of steps does not need to be increased. Forming the metal interconnect 90 at the same layer as that of the anode electrode 211 is also because of the same reason.

[0121] A contact hole 71_B is formed at the site between the pixels in the window insulating film 71 , i.e. the site at which the metal interconnect 90 is formed. Via this contact hole 71_B , the metal interconnect 90 is electrically connected to the organic layer 213 , specifically the charge injection layer 214 as the lowermost layer of the organic layer 213 in the present example.

2-2. Operation and Effect of Embodiment

[0122] The following operation and effect can be achieved by forming the metal interconnect 90 electrically connected to the organic layer 213 in such a manner that the metal interconnect 90 surrounds the periphery of the anode electrode 211 and setting the potential of the metal interconnect 90 to the cathode potential V_{cath} as described above. Specifically, when a leakage current flows in the lateral direction through the common layer in the organic layer 213 , specifically through the charge injection layer 214 and the connecting layers 216 and 217 in the present example, the leakage current flows into the metal interconnect 90 through the site of the contact hole 71_B (hereinafter, referred to as "contact part 71_B ") as shown in FIG. 12.

[0123] Thus, the leakage current flowing through the charge injection layer 214 completely flows into the metal interconnect 90 because this charge injection layer 214 is electrically connected to the metal interconnect 90 . That is, the leakage current flowing in the lateral direction through the charge injection layer 214 is completely blocked from flowing to the adjacent pixel side by the contact part 71_B .

[0124] The leakage current flowing in the lateral direction through the connecting layers 216 and 217 is divided into a component flowing into the contact part 71_B, a component flowing into the adjacent pixel side, and a component contributing to light emission. Therefore, the leakage current flowing through the connecting layers 216 and 217 can also be reduced compared with the case in which the metal interconnect 90 is not provided. In FIG. 12, the size of the arrow representing the light emission color conceptually indicates the intensity of this light. FIG. 13 shows the equivalent circuit of the display panel having the pixel structure according to the embodiment.

[0125] In this manner, the leakage current flowing into the adjacent pixel side can be reduced even when the leakage current flows in the lateral direction through the charge injection layer 214 and the connecting layers 216 and 217. This can suppress light emission in the adjacent pixel attributed to the leakage current and thus can achieve favorable color reproducibility (color purity).

[0126] In the present embodiment, the metal interconnect 90 surrounding the periphery of the anode electrode 211 is formed at the common layer with the anode electrode 211. However, the configuration is not limited thereto. Specifically, the layer at which the metal interconnect 90 is formed may be any layer as long as it is a layer that can be electrically connected to the organic layer 213 of the white organic EL element 21_w.

[0127] Furthermore, the potential of the metal interconnect 90 surrounding the periphery of the anode electrode 211 is set to the cathode potential V_{cath} in the present embodiment. However, the potential is not limited to the cathode potential V_{cath} but may be any potential as long as it is a potential lower than the potential of the anode electrode 211 in the non-light-emission state of the white organic EL element 21_w.

3. Modification Example

[0128] The above-described embodiment is explained by taking as an example the case of employing the system in which the respective color light beams of RGB are obtained by the combination of the white organic EL element 21_w and the color filter 80 and applying the system to the pixel structure (display panel) of the tandem structure. However, the present disclosure is not limited to this application example. Specifically, embodiments of the present disclosure can be applied to the overall organic EL display devices that do not employ the configuration of the tandem structure but have a pixel structure including at least one common layer formed in an organic layer in common to the pixels.

[0129] However, in the case of the pixel structure of the tandem structure, the connecting layers 216 and 217 to couple the light emitting units including the light emitting elements of the respective color light beams exist and a leakage current flows through these connecting layers 216 and 217. Thus, the problem associated with the leakage current is significant. Therefore, it can be said that the advantageous effects of the technique of the present disclosure are extremely large when an embodiment of the present disclosure is applied to the pixel structure of the tandem structure particularly.

[0130] Examples of other pixel structures including at least one common layer in an organic layer include a pixel structure employing the RGB mask separate-application system, in which organic EL materials of RGB are separately applied by evaporation with use of a mask. This pixel structure will be described with use of FIG. 14.

[0131] Referring to FIG. 14, the charge injection layer 214 is formed as a common layer on the anode electrodes 211_R, 211_G, and 211_B formed on a pixel-by-pixel basis and the window insulating film 71, and organic EL elements 21_R, 21_G, and 21_B of R, G, and B are formed on the charge injection layer 214. Furthermore, the cathode electrode 212 is formed on the organic EL elements 21_R, 21_G, and 21_B in common to all pixels, and the color filter 80 is formed in an on-chip form over the cathode electrode 212 with the intermediary of the interlayer insulating film 72.

[0132] In the case of the pixel structure employing the RGB mask separate-application system, the organic EL elements 21_R, 21_G, and 21_B of R, G, and B themselves emit the respective color light beams. Therefore, originally the color filter 80 is unnecessary. However, using the color filter 80 in combination provides an advantage that the color purity can be enhanced.

[0133] Also in the pixel structure employing the above-described RGB mask separate-application system, because of the existence of a common layer common to the pixels, specifically the charge injection layer 214 in the present example, the occurrence of the problem associated with a leakage current flowing into an adjacent pixel through this charge injection layer 214 is inevitable. Therefore, the above-described embodiment can be similarly applied also to a pixel structure that employs the RGB mask separate-application system and has a common layer among the pixels.

[0134] Specifically, in the pixel structure employing the RGB mask separate-application system shown in FIG. 14, a metal interconnect electrically connected to the organic layer (charge injection layer 214) is so formed as to surround the periphery of the anode electrodes 211_R, 211_G, and 211_B. In addition, the potential of this metal interconnect is set to a potential lower than the potentials of the anode electrodes 211_R, 211_G, and 211_B in the non-light-emission state of the organic EL elements 21_R, 21_G, and 21_B. Thereby, operation and effect similar to those of the above-described embodiment can be achieved.

4. Electronic Apparatus

[0135] The organic EL display device according to the above-described embodiment of the present disclosure can be applied to a display section (display device) of electronic apparatus in every field that displays a video signal input to the electronic apparatus or a video signal generated in the electronic apparatus as image or video. As one example, embodiments of the present disclosure can be applied to display sections of various pieces of electronic apparatus shown in FIG. 15 to FIG. 19G, specifically e.g. digital camera, notebook personal computer, portable terminal device such as a cellular phone, and video camcorder.

[0136] By using the organic EL display device according to one embodiment of the present disclosure as the display section of electronic apparatus in every field in this manner, the display quality of various kinds of electronic apparatus can be enhanced. Specifically, as is apparent from the explanation of the above-described embodiment, the organic EL display device according to one embodiment of the present disclosure can suppress light emission in an adjacent pixel even when a leakage current flows in the lateral direction through a common layer in an organic layer, and thus can achieve favorable color reproducibility (color purity). As a result, favorable displayed images having high quality can be achieved in various kinds of electronic apparatus.

[0137] The display device according to one embodiment of the present disclosure includes also a display device having a module shape based on a sealed configuration. As one example, a display module formed by applying an opposed section such as transparent glass to a pixel array section corresponds to such a display device. The display module may be provided with a circuit section, a flexible printed circuit (FPC), etc. for input/output of a signal and so forth from the external to the pixel array section.

[0138] Specific examples of the electronic apparatus to which one embodiment of the present disclosure is applied will be described below.

[0139] FIG. 15 is a perspective view showing the appearance of a television set to which one embodiment of the present disclosure is applied. The television set according to the present application example includes a video display screen section 101 composed of a front panel 102, a filter glass 103, etc. and is fabricated by using the organic EL display device according to one embodiment of the present disclosure as the video display screen section 101.

[0140] FIG. 16 is a perspective view showing the appearance of a digital camera to which one embodiment of the present disclosure is applied. FIG. 16A is a perspective view of the front side and FIG. 16B is a perspective view of the back side. The digital camera according to the present application example includes a light emitter 111 for flash, a display section 112, a menu switch 113, a shutter button 114, etc. and is fabricated by using the organic EL display device according to one embodiment of the present disclosure as the display section 112.

[0141] FIG. 17 is a perspective view showing the appearance of a notebook personal computer to which one embodiment of the present disclosure is applied. The notebook personal computer according to the present application example includes, in its main body 121, a keyboard 122 operated when characters and so forth are input, a display section 123 that displays images, etc. and is fabricated by using the organic EL display device according to one embodiment of the present disclosure as the display section 123.

[0142] FIG. 18 is a perspective view showing the appearance of a video camcorder to which one embodiment of the present disclosure is applied. The video camcorder according to the present application example includes a main body section 131, a lens 132 that exists on the front side and is used for subject photographing, a start/stop switch 133 operated in photographing, a display section 134, etc. and is fabricated by using the organic EL display device according to one embodiment of the present disclosure as the display section 134.

[0143] FIGS. 19A to 19G are appearance diagrams showing a cellular phone as an example of a portable terminal device to which one embodiment of the present disclosure is applied: FIG. 19A is a front view of the opened state, FIG. 19B is a side view of the opened state, FIG. 19C is a front view of the closed state, FIG. 19D is a left side view, FIG. 19E is a right side view, FIG. 19F is a top view, and FIG. 19G is a bottom view. The cellular phone according to the present application example includes an upper chassis 141, a lower chassis 142, a connecting part (in this example, hinge part) 143, a display 144, a sub-display 145, a picture light 146, a camera 147, etc. The cellular phone according to the present application example is fabricated by using the organic EL display device according to one embodiment of the present disclosure as the display 144 and the sub-display 145.

[0144] The present disclosure contains subject matter related to that disclosed in Japanese Priority Patent Application JP 2011-013049 filed in the Japan Patent Office on Jan. 25, 2011, the entire content of which is hereby incorporated by reference.

[0145] It should be understood by those skilled in the art that various modifications, combinations, sub-combinations and alterations may occur depending on design requirements and other factors in so far as they are within the scope of the appended claims or the equivalents thereof.

1-13. (canceled)

14. An organic electroluminescence display device comprising:

- a plurality of anode electrodes arranged in a matrix;
- a physically-unitary common layer having a plurality of light emission regions respectively corresponding to each of the anode electrodes, the physically-unitary common layer being formed on the anode electrodes and including at least one constituent-layer made of an organic material;
- a driving circuitry configured to selectively provide driving current to the anode electrodes such that each of the light emission regions selectively emits light;
- a metal interconnect directly electrically connected to the physically-unitary common layer;
- a common cathode electrode formed on the physically-unitary common layer,

wherein the driving circuitry is configured to:

- apply a first potential to the common cathode electrode, and
- apply a second potential to the metal interconnect, where the second potential is set such that, when the second potential is applied to the anode electrode corresponding to a given one of the light emission regions and the first potential is applied to the common cathode electrode, the given one of the light emission regions does not emit light.

15. The display device according to claim 14, wherein the metal interconnect is disposed between two of the anode electrodes.

16. The display device according to claim 14, wherein the metal interconnect is disposed so as to surround each of the anode electrodes.

17. The display device according to claim 14, wherein the metal interconnect is disposed on a same layer as the anode electrodes.

18. The display device according to claim 14, wherein the constituent-layer is a light emission layer and each of the light emission regions is configured to emit light of substantially the same color as one another.

19. The display device according to claim 18, further comprising a plurality of color filters respectively disposed so as to correspond to each of the light emission regions.

20. The display device according to claim 14, wherein the physically-unitary common layer includes a plurality of light emission layers stacked in a thickness direction, respectively configured to emit light of different colors.

21. The display device according to claim 20, wherein the physically-unitary common layer further includes an intermediate conductive layer disposed between the light emission layers.

22. An organic electroluminescence display device comprising:

- a plurality of pixel electrodes,
- a common organic layer continuously formed on the pixel electrodes, the common organic layer having a plurality of light emission regions configured to selectively emit light of substantially the same color as one another, each of the emission regions respectively corresponding to each of the pixel electrodes,
- a conductive layer formed on the common organic layer;
- a driving circuitry configured to drive each of the pixel electrodes; and
- a metal interconnect directly electrically connected to the common organic layer.

23. The display device according to claim **29**, wherein the driving circuitry is configured to:

- apply a first potential to the conductive layer, and
- apply a second potential to the metal interconnect, where the second potential is set such that, when the second potential is applied to the pixel electrode corresponding to a given one of the light emission regions and the first potential is applied to the conductive layer, the given one of the light emission regions does not emit light.

24. The display device according to claim **22**, further comprising a plurality of color filters respectively disposed so as to correspond to each of the light emission regions.

25. The display device according to claim **22**, wherein the common organic layer includes a plurality of light emission layers stacked in a thickness direction, respectively configured to emit light of different colors.

26. The display device according to claim **25**, wherein the common organic layer further includes an intermediate conductive layer disposed between the light emission layers.

27. The display device according to claim **22**, wherein the metal interconnect is disposed between two of the pixel electrodes.

28. An organic electroluminescence electronic apparatus comprising:

- a plurality of first electrodes;
- a physically-unitary common layer having a plurality of light emission regions respectively corresponding to each of the first electrodes, the physically-unitary common layer being formed on the first electrodes and including at least one constituent-layer made of an organic material;
- a driving circuitry configured to selectively provide driving current to the first electrodes such that each of the light emission regions emits light;
- a metal interconnect directly electrically connected to the physically-unitary common layer;

a second electrode formed commonly on the physically-unitary common layer,

wherein the driving circuitry is configured to:

apply a first potential to the common cathode electrode, and

apply a second potential to the metal interconnect, where the second potential is set such that, when the second potential is applied to the first electrode corresponding to a given one of the light emission regions and the first potential is applied to the second electrode, the given one of the light emission regions does not emit light.

29. The electronic apparatus according to claim **28**, wherein the physically-unitary common layer includes a plurality of light emission layers stacked in a thickness direction, respectively configured to emit light of different colors.

30. The electronic apparatus according to claim **29**, wherein the physically-unitary common layer further includes an intermediate conductive layer disposed between the light emission layers.

31. The electronic apparatus according to claim **28**, wherein the electronic apparatus is a device selected from a group consisting of a digital camera, a notebook personal computer, a portable terminal device and a video camcorder.

32. An organic electroluminescence display device comprising:

- a plurality of pixel electrodes,
- a common organic layer continuously formed on the pixel electrodes, the common organic layer having a plurality of light emission regions configured to selectively emit light of substantially the same color as one another, each of the emission regions respectively corresponding to each of the pixel electrodes,
- a conductive layer formed on the common organic layer;
- a driving circuitry configured to drive each of the pixel electrodes,
- a drainage electrode disposed in direct contact with the common organic layer, and configured to absorb charge that is provided from a given one of the pixel electrodes and is flowing through the common organic layer.

33. The display device according to claim **32**, wherein the drainage electrode is configured to prevent a current flowing from the given one of the pixel electrodes to an adjacent one of the light emission regions by absorbing the charge.

* * * * *

专利名称(译)	有机EL显示装置和电子设备		
公开(公告)号	US20140124765A1	公开(公告)日	2014-05-08
申请号	US14/072098	申请日	2013-11-05
[标]申请(专利权)人(译)	索尼公司		
申请(专利权)人(译)	索尼公司		
当前申请(专利权)人(译)	JOLED INC.		
[标]发明人	OMOTO KEISUKE		
发明人	OMOTO, KEISUKE		
IPC分类号	H01L27/32		
CPC分类号	H01L27/3248 G09G2300/0852 G09G2320/0209 G09G2320/046 H01L27/3211 H01L27/322 H01L27/3246 H01L51/5044 H01L51/5278 H01L51/5281 H01L2251/5315		
优先权	2011013049 2011-01-25 JP		
其他公开文献	US8987760		
外部链接	Espacenet USPTO		

摘要(译)

本发明公开了一种有机EL显示装置，其中每个包括通过在阳极电极和阴极电极之间插入有机层而形成的有机EL元件的像素以矩阵形式排列，该有机EL显示装置包括：公共层，被配置为包含在有机EL元件中并形成在像素共有的有机层中；金属互连件，被配置为围绕阳极电极的外围并且电连接到有机层，其中金属互连的电势被设置为低于有机体的非发光状态下的阳极电极的电势。EL元素。

